



SR1

AUTOLOADING HUNTING RIFLE

SERVICE MANUAL



CONTENTS

INTRODUCTION	3
1 DESCRIPTION AND OPERATION	4
1.1 Purpose of the rifle	4
1.2 Specifications	4
1.3 Main parts of the rifle	4
1.4 Design and operation of the rifle	5
1.5 Tools and accessories	5
1.6 Marking	6
2 USE FOR DESIGNATED PURPOSE	6
2.1 Operating restrictions	6
2.2 To prepare the rifle for use	6
2.3 To use the rifle	8
3 MAINTENANCE	9
3.1 General instructions	9
3.2 Field stripping	10
3.3 To reassemble after field stripping	13
3.4 Detail stripping	15
3.5 To reassemble after detail stripping	18
3.6 To mount attachments and mounting parts	20
3.7 To adjust muzzle brake	22
3.8 Purpose of tools and accessories	22
3.9 Cleaning and lubrication	23
4 TRANSPORTATION	24
5 STORAGE	24
6 COMPLETE SET	25
APPENDIX A (normative)	26
APPENDIX B (normative)	28



WARNING! BEFORE USING THE SR1 AUTOLOADING HUNTING RIFLE, FOR YOUR SAFETY AND THE SAFETY OF OTHERS READ CAREFULLY AND UNDERSTAND THIS SERVICE MANUAL PAYING SPECIAL ATTENTION TO THE FIREARM SAFETY RULES AND PRECAUTIONS.

This Service Manual (hereinafter referred as the Manual) covers the SR1 autoloading hunting rifle (hereinafter referred to as the rifle) with the balanced action.

The Manual describes the rifle design, principle of operation, specifications and other information for the correct and safe operation of the rifle.

The rifle design provides its safe functioning if observing requirements of the Manual.

Some minor design alterations may be not included in the Manual as the rifle is under constant development.

Appendix A contains the rifle parts and their names.



WARNING! WHEN USING THE RIFLE, THE DANGERY MAY COME FROM:

- AT SHOOTING – THE BULLET DISCHARGED AT SHOT; HOT POWDER GASES; BURST WAVE; RECOIL; EXTRACTED CARTRIDGE CASE; PROTRUDING CHARGING HANDLE; AND RIFLE HOT PARTS (BARREL, MUZZLE BRAKE, GAS CYLINDER).
- AT SERVICING – PRESERVATION AGENTS OF THE FACTORY PACKING; SPRINGS THAT ARE COMPRESSED OR ARE TO BE COMPRESSED DURING DISASSEMBLY-REASSEMBLY PROCESS.



1 DESCRIPTION AND OPERATION

1.1 Purpose of the rifle

The SR1 autoloading hunting rifle under 223 Rem. is intended for game and big fowl hunting under various climatic conditions.

General view of the rifle is shown in Fig. 1.1.

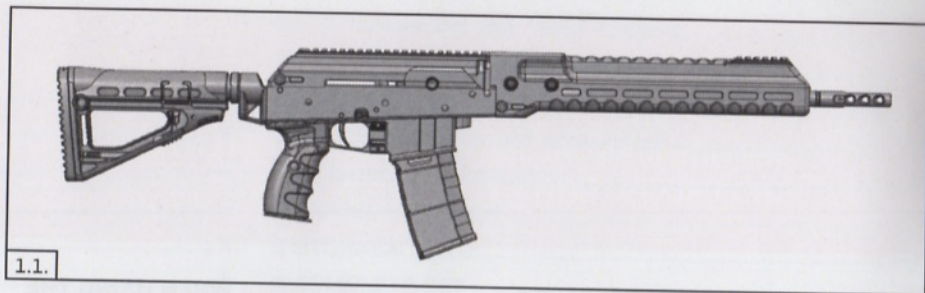

1.2 Specifications

1.2.1 The rifle specifications are given in Table 1.

1.3 Main parts of the rifle

1.3.1 Main parts of the rifle are given in Appendix A.

The rifle is delivered without sighting devices. There are Picatinny rails on the receiver cover and the fore-end for the customer to mount scopes. Your scope system should have a base to fit the Picatinny rail.

Table 1

Parameter	Value	
	SR1	SR1-01
Caliber, mm	5.56	5.56
Cartridge	223 Rem.	223 Rem.
Magazine capacity, rounds, max	10	10
Weight with empty magazine, kg, max	4.25	4.45
Overall length, mm, max:		
- buttstock is fully forward	922	1022
- buttstock is fully rearward	1022	1122
Barrel length, mm	415	515
- pitch of rifling	229	229



1.4 Design and operation of the rifle

The rifle is reloaded automatically due to the energy of powder gases escaping from the bore to the gas block as well as the energy of the return springs.

The rifle action is based on two moving systems: a carrier and bolt and a rack that are linked with two sprockets (gears). Each moving system has its gas piston receiving the gas from the gas block.

The bolt is locked by rotating about its axis to the right, thereby the bolt lugs engage the receiver lugs.

When the carrier and the bolt move forward due to the return spring and the rack spring, the cartridge goes from the magazine to the chamber. The bolt rotates and locks the bore, the hammer sets at the trigger shaped lug and the extractor engages the rim of the cartridge case.

When the trigger is pulled, the hammer releases and while being turned by the mainspring strikes the firing pin. A shot is fired. Pressure gas from behind the shot charge passes through the barrel port to the gas block. Expanding in the gas block,

the gas pushes the pistons and forces the carrier and the bolt to the rear and the rack forward. As the carrier continues rearward, the bolt gets unlocked, extracts the case from the chamber and expels it with the ejector tooth from the receiver. The hammer is cocked due to the carrier and engages with the sear. As the carrier and the bolt are fully rearward and the rack is fully forward, they synchronously strike against the carriage. Due to the return springs the carrier and bolt go forward while the rack goes backwards. The bolt engages the next cartridge from the magazine and send it onto the chamber. To make the next shot, release and pull the trigger.

When the trigger is released, the sear disengages the hammer and the hammer sets at the trigger shaped lug. Synchronous impact of the two moving systems at the fully rear and front positions (balanced action) mitigates the impact against the receiver and reduces the rifle recoil at firing.

The safety mechanism locks the trigger and protects against accidental discharge.

1.5 Tools and accessories

The container with a single set of accessories is in the rifle pistol grip. The single set of accessories is used for the rifle disassembly, reassembly, cleaning and lubrication and consists of a screwdriver, drift, brush and a pull-through.



1.6 Marking

The rifle receiver is marked with the serial number, model name, trademark and country of manufacture as well as the following special marks and symbols:

223 Rem. – name of the cartridge used;



– proof mark of the C.I.P.
(Permanent International
Commission for the Proof of
Small Arms) accredited Proof
House (PH)



and the year of proofing the rifle;

CIP
N

– standard proof mark of the
C.I.P. for normal proof-tests

The PH proof mark and C.I.P. standard proof mark are also imprinted on the barrel and the bolt.

2 USE FOR DESIGNATED PURPOSE

2.1. Operating restrictions

Before using the rifle, you must read this Manual to understand and learn the rifle design and mechanics. Pay special attention to the safety precautions. For shooting, use 223 Rem. sporting and hunting cartridges with the relevant Certificate of Conformity.



WARNING! IF AMMUNITION EXPIRY DATE IS NOT SPECIFIED ON THE AMMUNITION PACK YOU BOUGHT, THE AMMUNITION SHELF LIFE SHOULD NOT EXCEED 12 MONTHS OF ITS MANUFACTURING DATE. THE DATE AND THE YEAR OF THE AMMUNITION MANUFACTURE ARE SPECIFIED ON THE BOX.

The ammunition should be stored tight packed. Extended storage changes ammunition powder properties therefore expired cartridges may cause dangerously high pressure in the bore or pressure

insufficient to discharge the bullet from the barrel. The bullet gets lodged in the bore and the next shot also results in the dangerously high pressure in the bore. Both situations are hazardous and may destroy the rifle and cause serious personal injury or death. When imitating the shot, place a fired case in the chamber to avoid breaking of the firing pin.

2.2 To prepare the rifle for use

2.2.1 Safety Precautions

The rifle design provides its safe functioning if operating properly and using ammunition with the relevant Certificate of Conformity.

For the rifle safe handling, you must observe the following precautions:

- always treat the rifle as if it is loaded;
- never point the muzzle to people, never rest on the rifle;
- having taken the rifle, make sure the magazine and the chamber do not contain ammunition by detaching the magazine, moving the carrier to the rear



and visually checking the magazine and the chamber;

- do not dry fire to avoid breaking of the firing pin, unless necessary;
- before loading the rifle, visually check the bore and the chamber to be certain they are clean and free of obstructions;
- when loading and unloading, keep the muzzle pointed in a safe direction;
- always hold the rifle with the safety set at safe to avoid accidental discharge. Never place your finger on the trigger unless you are ready to discharge;
- keep in mind the bullet can ricochet at firing from hard flat surfaces or water;
- if misfire occurs, do not unlock the bolt for 3 min due to the risk of the hang fire;
- unload the rifle when moving within hunting areas, before approaching an inhabited area and a camp or before getting on a car;
- always transport the rifle unloaded;
- store the rifle in a location separate from the ammunition;
- keep record of the fired shots.

If the sound of the shot is irregular, no reloading after the shot occurs or the cartridge fits into the chamber too tightly, you must stop firing, unload and disassemble the rifle, visually check the bore and the chamber, then check the shotgun functioning. If any visible defects of the barrel, receiver or bolt or ruptures of the case bottom occur, you must stop using the rifle. Use factory-loaded ammunition free from corrosion, with no apparent defects and with unexpired shelf life.



WARNING! IT IS STRICTLY PROHIBITED TO USE AMMUNITION OF INCORRECT CALIBER AND HAND-LOADED AMMUNITION!

Remember that the use of hand-loaded, expired, corroded ammunition or ammunition not intended for this rifle may result in the rifle destruction due to the dangerously high pressure of powder gases. The cartridge specifications allow cracks on the fired case at min 5mm distance from the extractor groove, on

the case neck and shoulder unless there are no powder gases escaping between the case body and the chamber first cone, therefore such cracks do not mean the rifle is defective. The Manufacturing plant bears no responsibility for the rifle or rifle parts breakdown that result from the non-observance of the safety precautions laid down in the present Section by the User.

2.2.2 Procedure to prepare the rifle for use

Use the following procedure to prepare the rifle:

- wipe the bore, chamber and the gas block dry and remove the lubricant from outer surfaces of all parts;
- mount a scope to the Picatinny rail with the convenient location of the eyepiece from the eye (take recommendations for the scope from its manual into account);
- place a fired case into the chamber and make a dry fire to test the rifle function;
- check accuracy of fire, if necessary adjust sighting devices (follow the adjustment procedure from the manual for the



scope) since the accuracy depends on individual parameters of a shooter as well as the type and lot of cartridges, weather conditions and other factors.

The rifle is ready for use.

2.2.3 Zeroing

The rifle has no open sighting devices. The rifle zeroing is performed at the selected distance by the shooter on its own. To zero the rifle, use your optical device compatible with the Picatinny rail. See the scope adjustment procedure at zeroing in the scope manual.

2.3 To use the rifle

2.3.1 To engage/disengage the safety:

- set the loaded rifle at safe by shifting the safety to the 'safe' position (Fig. B.1). The trigger is blocked.
- disengage the safety by shifting the safety to the 'fire' position.

2.3.2 To load and fire the rifle:

- press the magazine release button (Fig. B.2, B.3) for the magazine to drop under its own weight from the rifle;
- load the magazine by pushing cartridges one by one under the magazine lips fully to the magazine rear wall (magazine capacity is max 10 rounds);
- attach the loaded magazine to the rifle;

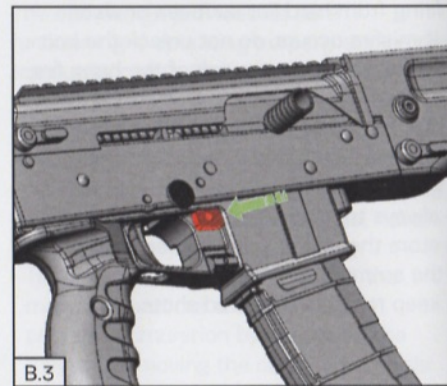
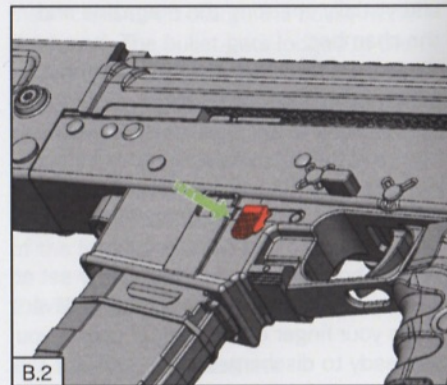
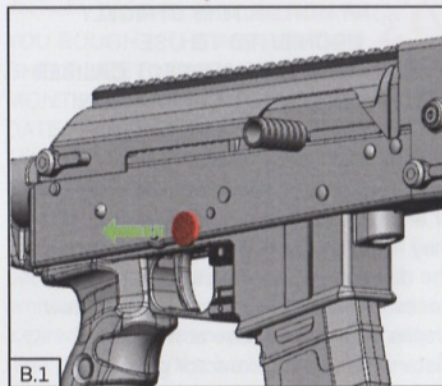



ATTENTION: IF THE COMPLETELY LOADED MAGAZINE FITS THE RIFLE TOO TIGHTLY, IT IS RECOMMENDED TO ATTACH IT WITH THE CARRIER HOLD OPEN WITH THE BOLT STOP.

– shift the safety to the ‘fire’ position, pull the carrier fully rearward and release it abruptly.

The rifle is loaded and ready for firing.

Pull the trigger to discharge. For the next shot release the trigger and pull again. As soon as the magazine is empty, the bolt holds open with the bolt stop. To unlock the bolt, detach the magazine. Then attach the loaded magazine to the rifle and shift down the bolt stop button (Fig. B.4, B.5). The cartridge is chambered. The rifle is ready for firing.

2.3.3 To unload the rifle:

Use the following procedure:

- engage the safety;
- detach the magazine;
- disengage the safety;
- pull the action fully rearward and extract the chambered cartridge;
- move the action forward, keeping the rifle pointed in a safe direction;
- pull the trigger keeping the rifle pointed in a safe direction;
- engage the safety;
- unload the magazine.

3 MAINTENANCE

3.1. General instructions

Maintenance includes visual checking, cleaning and lubricating of the rifle while field or detail stripping. Perform the field stripping to visually check the rifle and to clean and lubricate it after shooting. Perform the detail stripping to clean the rifle whenever it has been exposed to mud, dirt, rain, snow or when the new lubricant

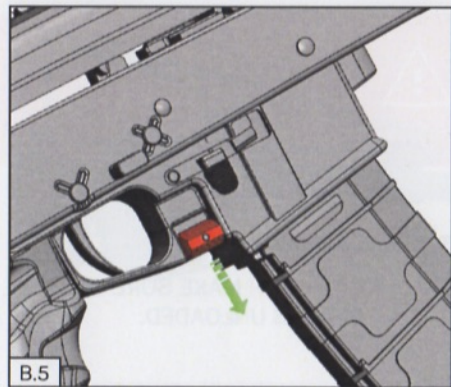
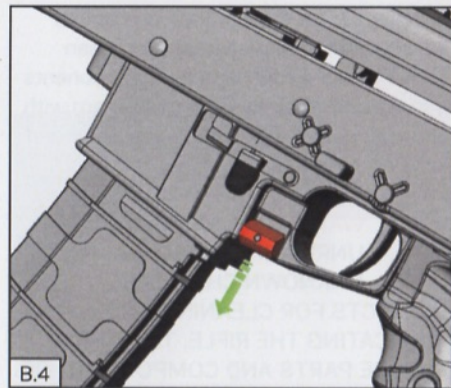



is applied or for repair. Disassemble and reassemble the rifle on a table or clean cloth. Place the rifle parts and components in the disassembly order, handle them with care, do not put them onto each other and avoid excessive force and impacts.



WARNING! AVOID USING UNRECOMMENDED OR UNKNOWN CHEMICAL PRODUCTS FOR CLEANING AND LUBRICATING THE RIFLE. THEY MAY DAMAGE PARTS AND COMPONENTS OF THE RIFLE!



RECOMMENDATION: THE USE OF KALASHNIKOV CLEANING PRODUCTS AND LUBRICANTS IS STRONGLY RECOMMENDED.

3.2 Field stripping



WARNING! MAKE SURE THE RIFLE IS UNLOADED.

To disassemble:

- detach the magazine with the safety engaged (Fig. B.6), disengage the safety, pull the charging handle fully rearward (Fig. B.7), visually check the chamber to be certain there is no cartridge, move the action forward;
- detach the cover with integrated Picatinny rail. Turn the lock handle by 180° (Fig. B.8) and pull the cover upward to disengage the handle from the receiver butt-plate (Fig. B.9). Then move the cover rearward to disengage the cover

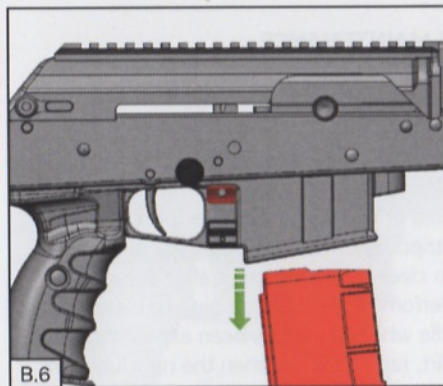

B.6

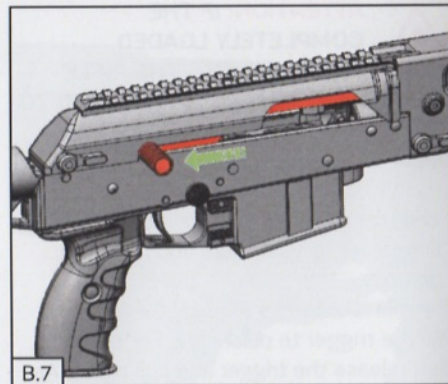

B.7

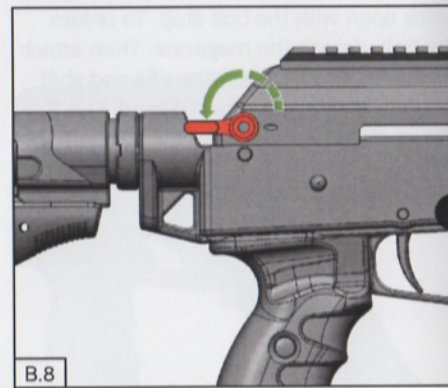

B.8

from the receiver (Fig. B.10);

- detach the fore-end by turning the lock handle by 180° (Fig. B.11) and pulling the fore-end forward (Fig. B.12);
- detach the rack by pulling its rear upward (Fig. B.13). As the carriage disengages from the receiver, move the rack forward and remove the rack gas piston from the gas block (Fig. B.14);
- detach the retracting mechanism by moving the return-spring base forward. As the base disengages from the groove of the butt-plate (Fig. B.15), raise

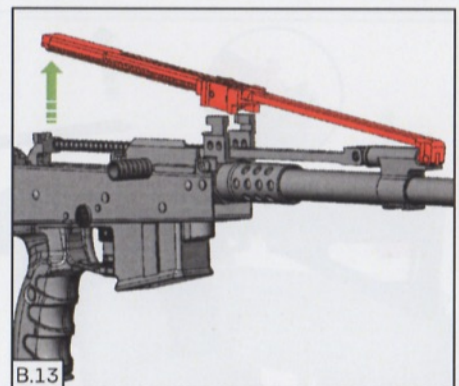
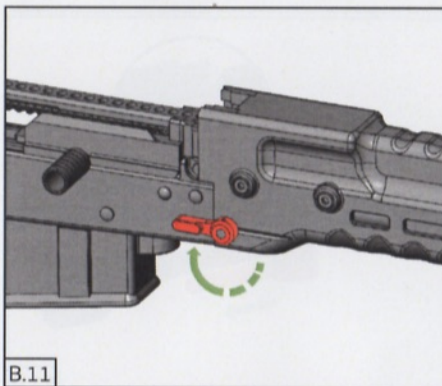
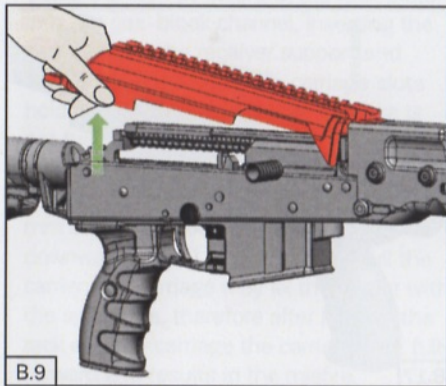
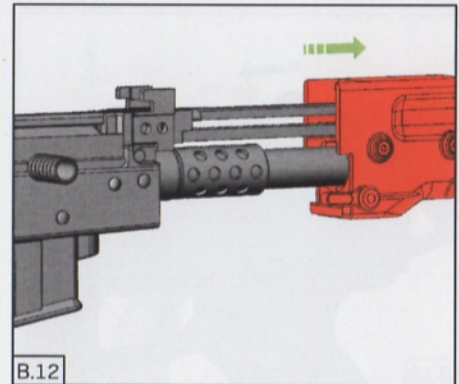
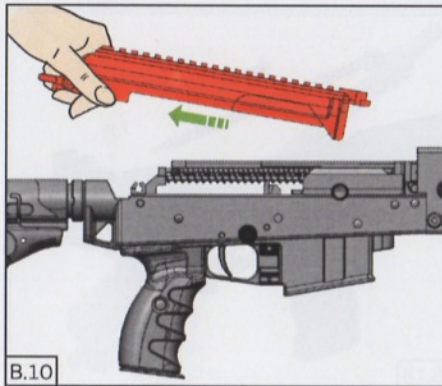

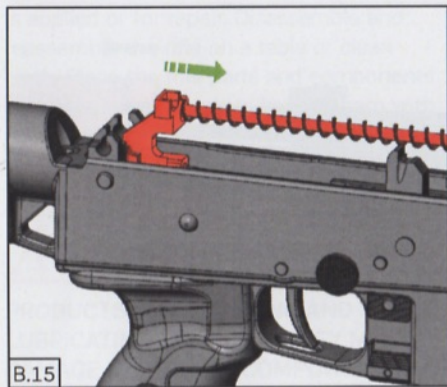

B.15

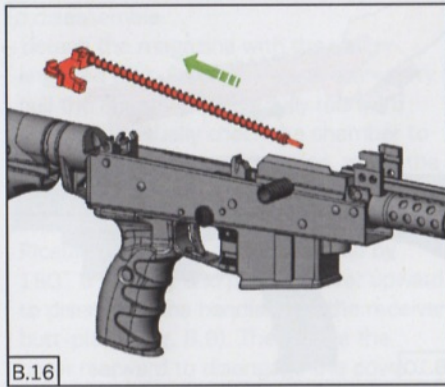

B.16

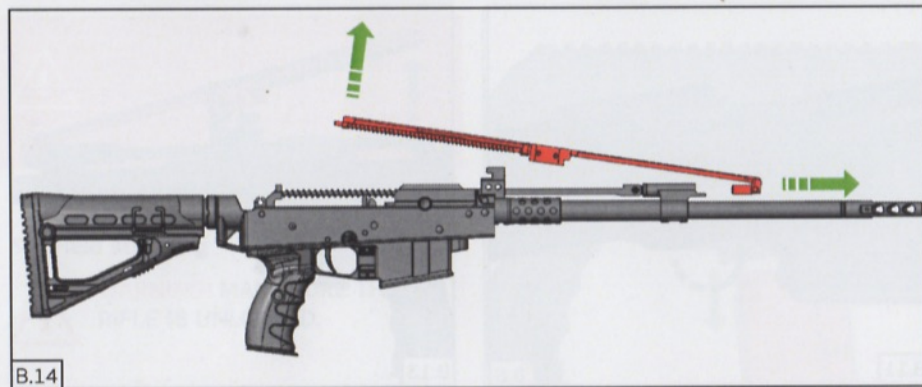

B.14

it slightly and remove the rod of the retracting mechanism from the carrier and receiver (Fig. B.16);

- detach the carrier and bolt by pulling the carrier fully rearward, raising slightly and removing from the receiver (Fig. B.17);
- detach the bolt from the carrier by pulling the bolt fully rearward. Turn the bolt until the bolt rhomb lug disengages from the carrier shaped slot and remove the bolt forward (Fig. B.18).

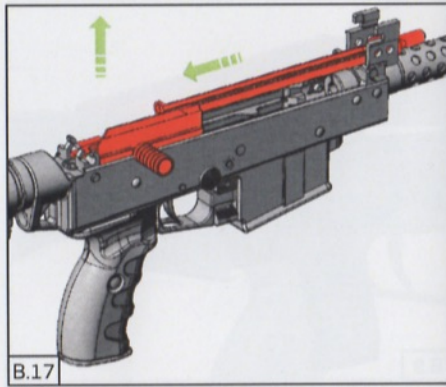

B.17

3.3 To reassemble after field stripping

Use the following procedure:

- attach the bolt to the carrier (Fig. B.19);
- place the carrier and bolt into the receiver (Fig. B.20);
- attach the retracting mechanism. Place the retracting-mechanism rod into the carrier and the receiver, push it fully forward, engage the lugs of the return-spring base with the butt-plate groove and pull the retracting mechanism fully rearward (Fig. B.21);
- place the rack by inserting the rack piston into the gas-block channel, inserting the carriage into the receiver support and lowering the carriage. The carriage slots hold the support guides. The carriage is not fully downward, resting in the carrier. To place the rack and carriage correctly, pull the carrier rearward max 1 or 2 mm and seat the carriage by moving downward (Fig. B.22). If you overpull the carrier, the carriage may fix the carrier with the sprockets, therefore after placing the rack and the carriage the carrier is not fully forward and results in the misfire.

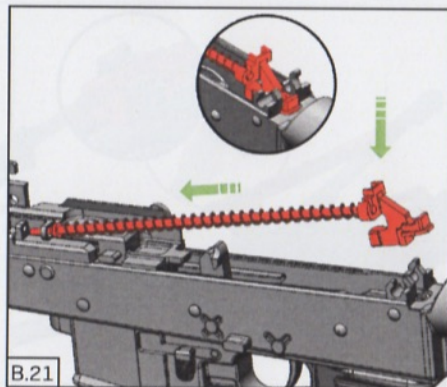
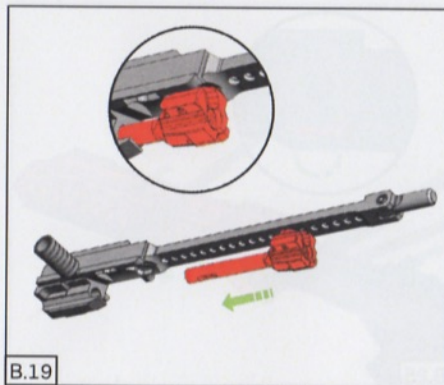
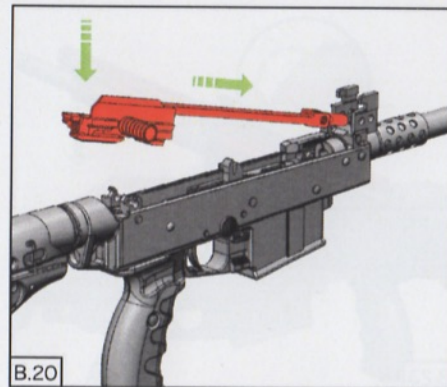
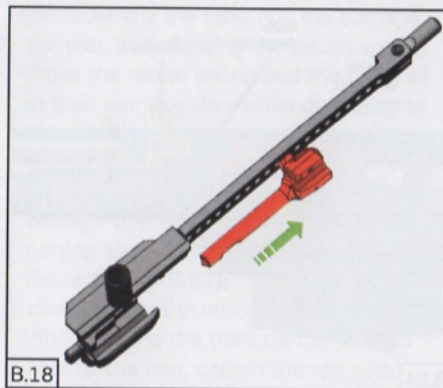

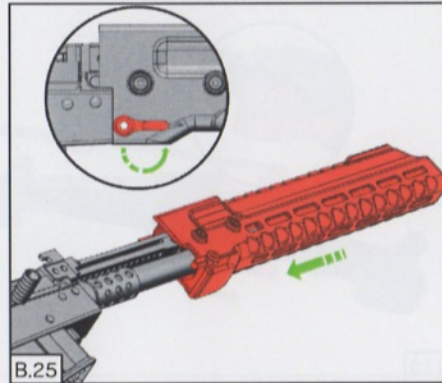
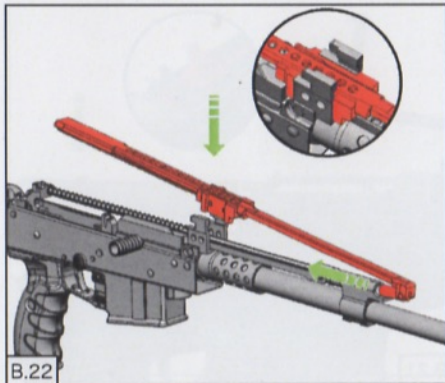
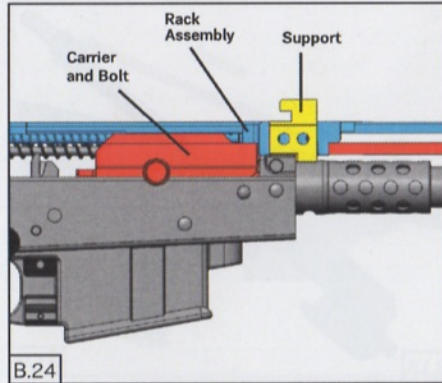
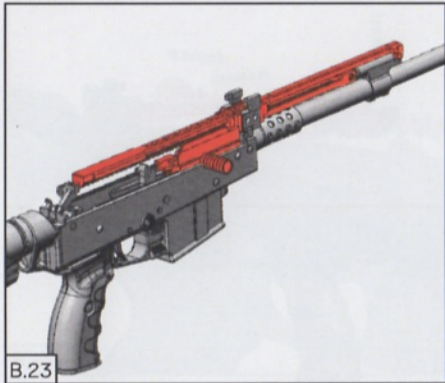

WARNING! AFTER PLACING THE RACK AND CARRIAGE, MAKE SURE THE CARRIER IS FULLY FORWARD (Fig. B.23, B.24).

- attach the fore-end by placing it onto the barrel until the receiver and turning the lock handle by 180° until it goes click (Fig. B.25);
- attach the receiver cover by engaging the rail fully forward into the receiver support. Push the cover in the rear to engage the lock with the butt-plate. Turn the lock handle by 180° until it goes click (Fig. B.26).

3.4 Detail stripping

Perform detail stripping each time the rifle has been exposed to mud, dirt, humidity or the rifle is to be stored.



WARNING! SPRINGS OF THE RETRACTING MECHANISM AND THE MAGAZINE ARE UNDER COMPRESSION. IF SUDDENLY RELEASED, THEY MAY CAUSE PERSONAL INJURIES TO YOU AND PEOPLE AROUND YOU.



WARNING! TO ENSURE PROPER DISASSEMBLY AND REASSEMBLY YOU ARE RECOMMENDED TO HAVE YOUR RIFLE SERVICED BY A COMPETENT SPECIALIST OR AUTHORIZED REPAIR CENTRE.

To perform detail stripping, use tools as assigned. You may use a hammer to detach pins if necessary but avoid excessive force. Use the following detail-stripping procedure:

- perform field stripping (Section 3.2.);

- disassemble the rack. Pull the carriage to the rear, compressing the return spring. Press the return spring and the rack rod in their rear position; while disengaging the rod from the carriage seat, return the carriage to the front position. Detach the return spring from the rod. Pull the carriage to the rear position and while turning about the axis disengage it from the rack (Fig. B.26);
- disassemble the retracting mechanism. While holding the front part of the rod against the rest, detach the rod with

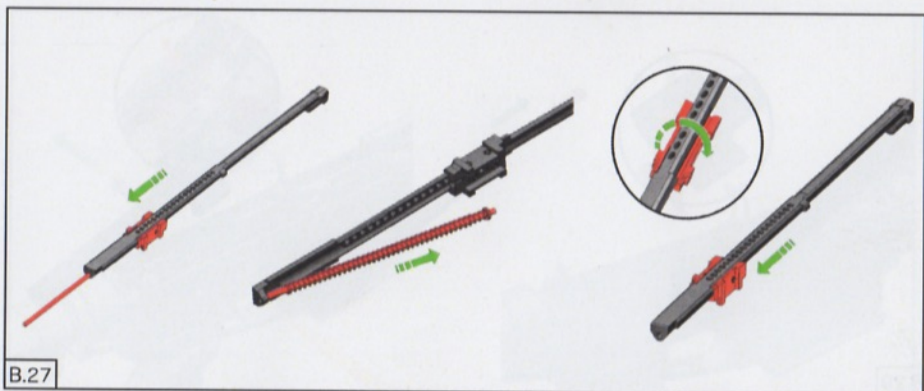
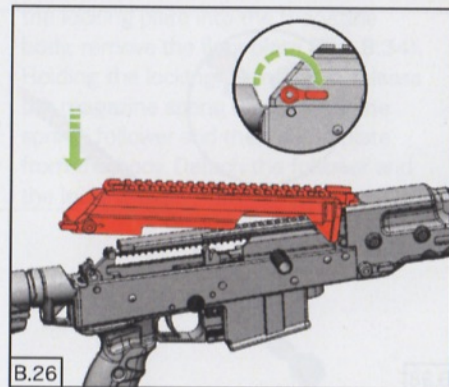

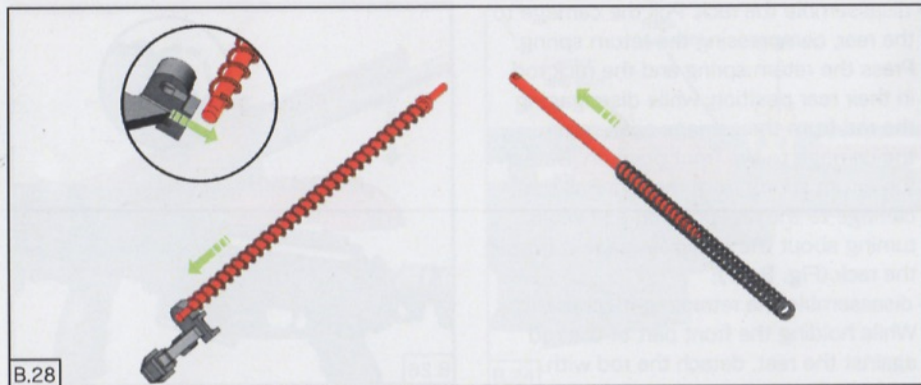

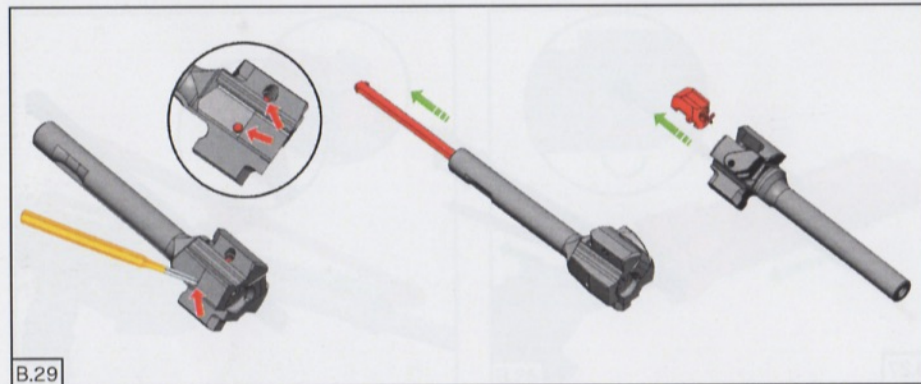

return spring from the base and remove the spring and washer from the rod (Fig. B.28);

- disassemble the bolt assembly by forcing out the firing-pin stud and the extractor pin with the drift, removing the firing pin and the extractor with springs from the bolt. While holding the pressed hook of the extractor, remove the extractor with spring from the bolt slot (Fig. B.29);



 **WARNING!** SPRINGS OF THE EXTRACTOR AND THE FIRING PIN ARE UNDER COMPRESSION. WHILE REMOVING THE PINS, THE EXTRACTOR OR THE FIRING PIN MAY THROW OUT DUE TO THE SPRINGS.

- remove the trigger mechanism as follows:
 - a) raise the ends of the mainspring one by one with the drift and engage them with the hammer cocking cam (Fig. B.30);

 **WARNING! TO AVOID THEIR SEPARATION, HAVE THE ENGAGED ENDS TIED WITH SOFT WIRE.**

- b) disengage the longer end of the trigger-mechanism spring from the circular groove of the trigger mechanism with the screwdriver, push out the pin with the drift, and extract the trigger mechanism from the receiver (Fig. B.31);
- remove the hammer by pushing out the pin with the drift, turning the hammer

with mainspring inside the receiver by 90° and extracting from the receiver (Fig. B.32). Separate the ends of the mainspring, disengage them from the hammer lugs and remove the spring from the hammer trunnions;

- extract the safety lever (Fig. B.33);
- disassemble the magazine. Make certain it is completely unloaded. Use the drift to sink the lug of the locking plate fully into the hole of the magazine floor plate and move the floor plate slightly to the front with the thumb. While keeping

the locking plate into the magazine body, remove the floor plate (Fig. B.34). Holding the locking plate, slowly release the magazine spring and remove the spring, follower and the locking plate from the body. Detach the follower and the locking plate from the spring.

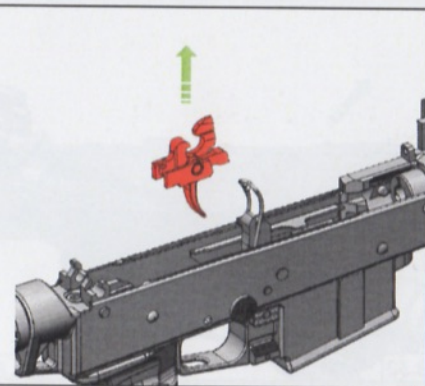
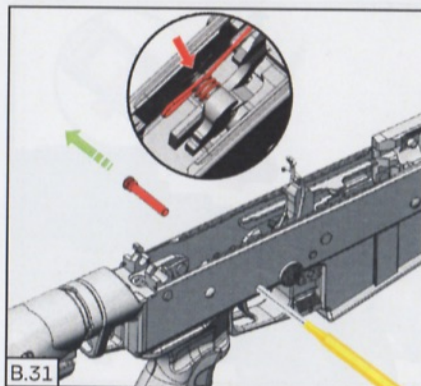
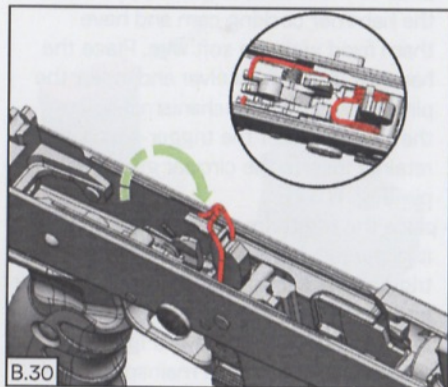

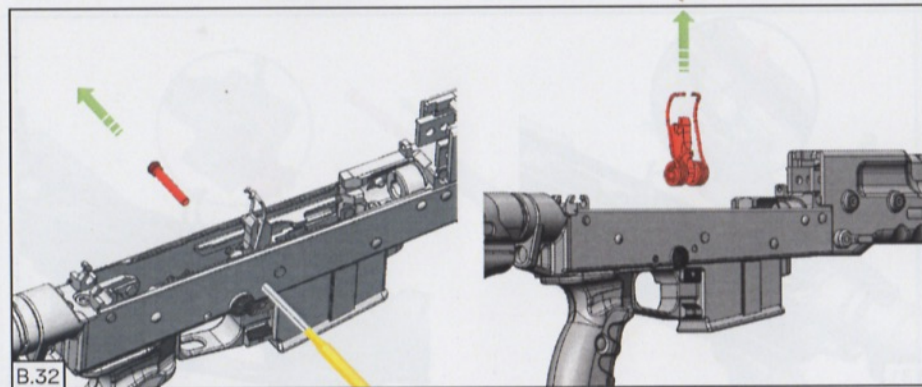
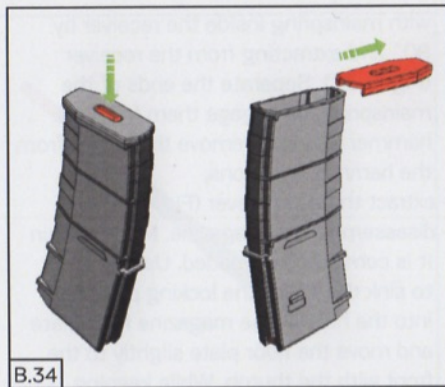
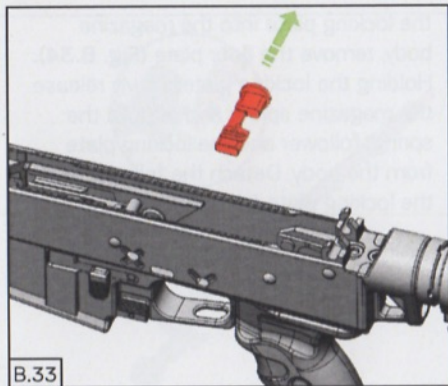

3.5 To reassemble after detail stripping

Use the following procedure:

- reassemble the magazine. Place the follower, spring and the locking plate into the magazine. Holding the locking plate, place the magazine floor plate. Ensure the locking plate lug inserts the floor plate hole (Fig. B.35);
- place the safety lever (Fig. B.36);
- place the hammer. Place the mainspring on the hammer trunnions, engage the ends of the mainspring one by one with the hammer cocking cam and have them fixed with the soft wire. Place the hammer into the receiver and insert the pin of the trigger mechanism. Ensure the longer end of the trigger-mechanism retainer inserts the circular groove of the pin (Fig. B.37);
- place the trigger mechanism by inserting it in the receiver and mounting the trigger-mechanism pin. Ensure the longer end of the trigger-mechanism spring inserts the circular groove (Fig. B.38);
- release the ends of the mainspring and

- place them one by one on the trigger lugs (Fig. B.39);
- reassemble the bolt (Fig. B.40);
 - reassemble the retracting mechanism. Place the spring and washer onto the rod. Reassemble the base and rod by compressing the spring on the rod and fixing it with the thumb. Insert the rod with spring in the base, aligning the rod slots with the base hole. Release the spring (Fig. B.41);

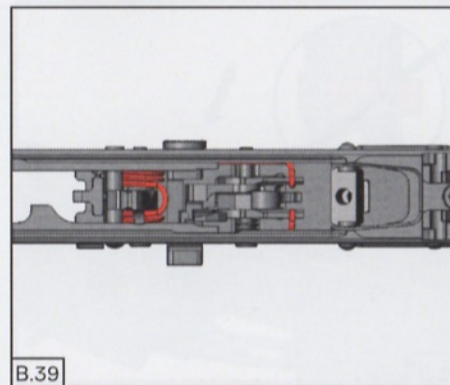
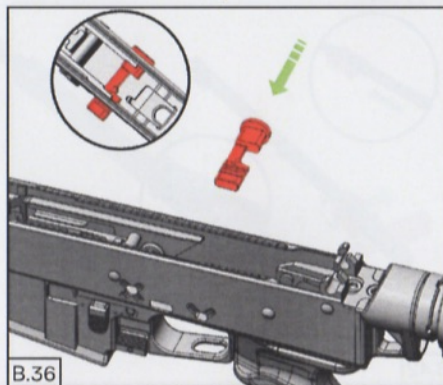
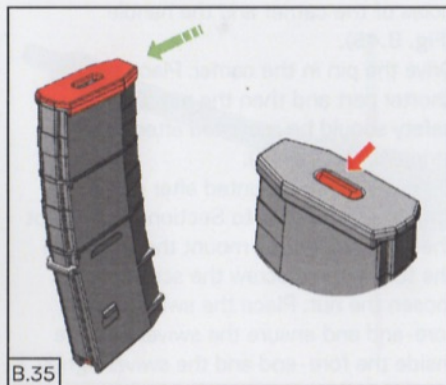
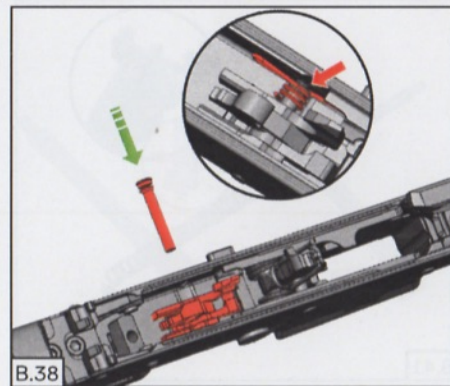
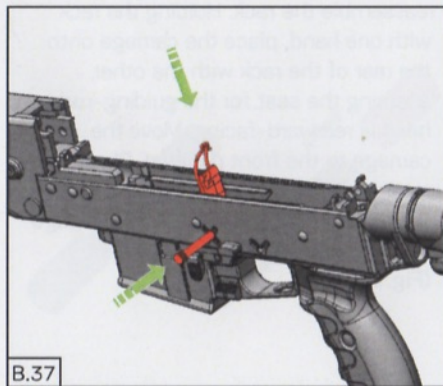

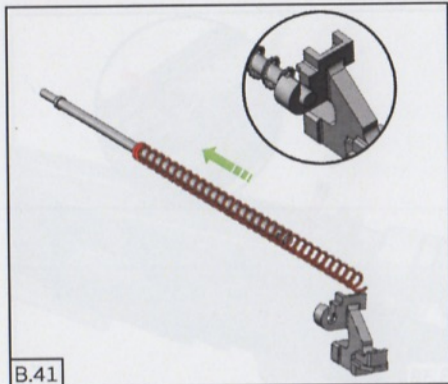

B.41

– reassemble the rack. Holding the rack with one hand, place the carriage onto the rear of the rack with the other, ensuring the seat for the guiding-rod head is rearward-facing. Move the carriage to the front position. Place the return spring on the rod, press it, insert the rod end in the rack hole and engage the rod head into the carriage seat (Fig. B.42).

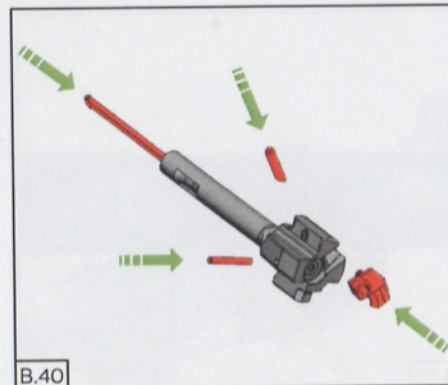

B.40

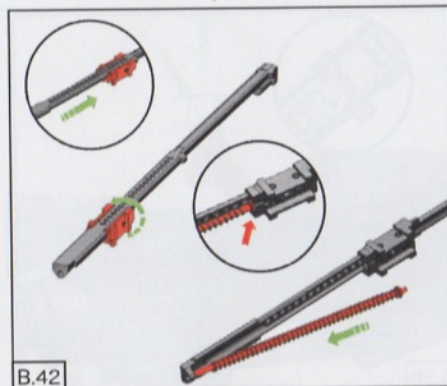

B.42

3.6 To mount attachments and mounting parts

Mount the ambidextrous charging handle after detaching the bolt from the carrier (Fig. B.18). Push out the pin from the inner side of the carrier with the drift (Fig. B.43). Remove the one-sided handle from the carrier. Before placing the ambidextrous handle, disassemble it by pushing the pin out from the handle and detaching the shorter part from the longer one (Fig. B.44). Insert the longer part in the carrier from the right side and align the holes of the carrier and the handle (Fig. B.45).

Drive the pin in the carrier. Place the shorter part and then the pin. The left safety should be mounted after detail stripping (Fig. B.46).

Other parts are mounted after detail stripping according to Section 3.5 (except the right safety). To mount the swivel on the fore-end, unscrew the screws and loosen the nut. Place the swivel on the fore-end and ensure the swivel lugs are inside the fore-end and the swivel tightly

fits the fore-end surface (Fig. B.47). Tighten the screws, and the nuts must rotate by 90°. To mount the rail on the fore-end, unscrew the screw and loosen the nut. Place the rail on the fore-end and ensure the rail lugs are inside the fore-end and the rail fits tightly the fore-end surface (Fig. B.48). Tighten the screws, and the nuts must rotate by 90°.

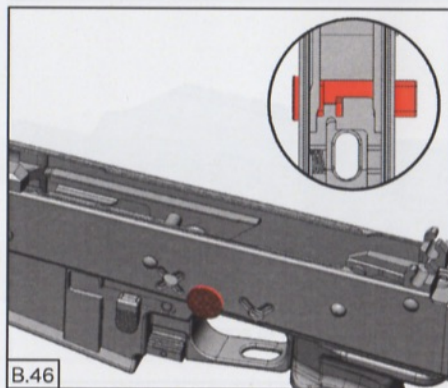
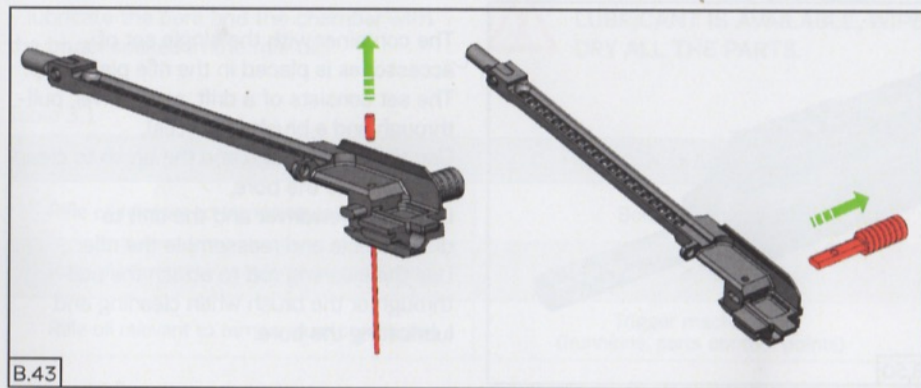
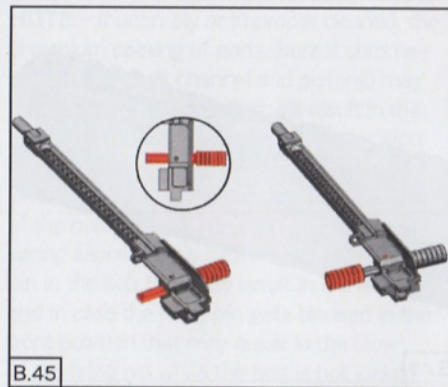
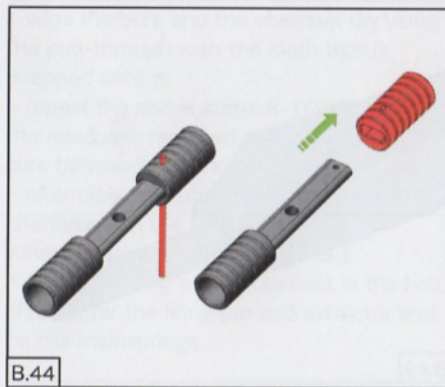

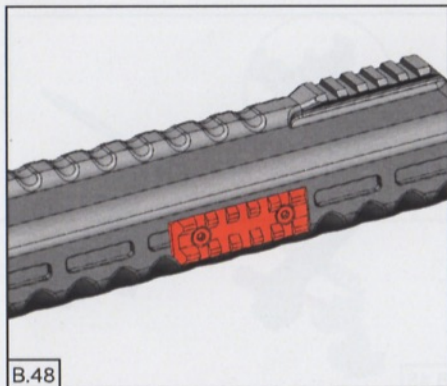

B.48

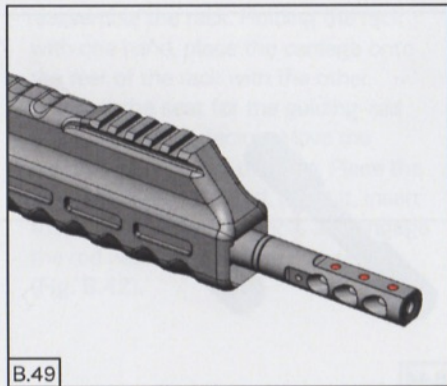

B.49

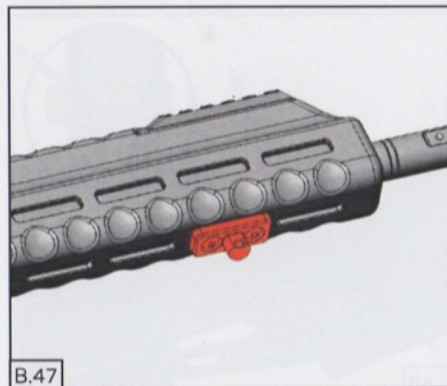

B.47

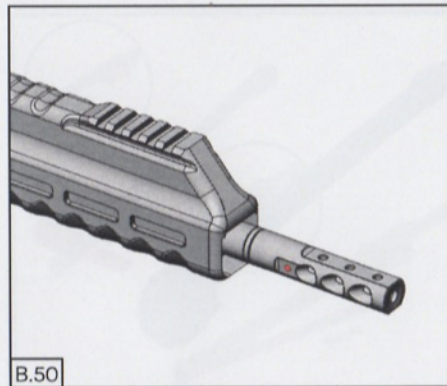

B.50

3.7 To adjust muzzle brake

Adjust the muzzle brake by reaming or drilling adjusting slots and holes. If the rifle moves up from the sight line after the shot, ream the hole on the top of the muzzle brake (Fig. B.49). If the rifle moves to the right from the sight line, drill a hole from the RIGHT side of the muzzle brake (Fig. B.50). If the rifle moves to the left from the sight line, drill a hole from the LEFT side of the muzzle brake.

3.8 Purpose of tools and accessories

The container with the single set of accessories is placed in the rifle pistol grip. The set consists of a drift, screwdriver, pull-through and a brush (3 pieces). Use the pull-through and the brush to clean and lubricate the bore. Use the screwdriver and the drift to disassemble and reassemble the rifle. Use the cleaning rod to attach the pull-through or the brush when cleaning and lubricating the bore.



3.9 Cleaning and lubrication

As soon as firing is over, inspect, clean and lubricate the rifle using the set of accessories. In winter clean the rifle indoors at temperature $(20 \pm 5)^{\circ}\text{C}$ after the rifle has warmed up to the indoor temperature. To clean the bore and chamber, use a clean cloth (rag, tow) without sand or any solids. If it is impossible to clean the rifle immediately after shooting, lubricate the bore according to **Table 3.1**.

Use the following procedure to clean the rifle:

- lubricate the bore and the chamber with the brush soaked in the rifle oil;

- wipe the bore and the chamber dry using the pull-through with the cloth tightly wrapped onto it;
 - repeat the above steps 8-10 times until the residue is removed completely (make sure by visually checking the bore);
 - after cleaning, lubricate the bore and the chamber with the clean rifle oil.
- When lubricating, follow **Table 3.1**. Avoid thickening of the lubricant in the bolt channel for the firing pin and extractor and on the mainsprings.



WARNING! IF NO SUITABLE LUBRICANT IS AVAILABLE, WIPE DRY ALL THE PARTS.

NOTE - If untimely or improper cleaned, the chromium coating of parts (bore if chrome-plated, gas block channel and pistons) may crack and corrode and that will result in the rifle failure and poor accuracy and precision of fire.

Untimely or improper cleaning and lubrication of the bolt channel, firing pin and firing-pin spring causes heavy movement of the firing pin in the bolt that may result in the misfire, and in case the firing pin gets blocked in the front position that may result in the blow of the firing pin while the bolt is not locked completely.

Table 3.1

Lubricant description	Part to lubricate	How to apply lubricant
Rifle oil relevant to temperature conditions	Bore and chamber	Using the brush
Rifle oil relevant to temperature conditions	Bolt	Wiping
Rifle oil relevant to temperature conditions	Trigger mechanism (trunnions, parts contact points)	Applying drops of oil



4 TRANSPORTATION

4.1 You may transport the rifle by any transport in covered vehicles. Transport the rifle cased to avoid impacts and falls.

4.2 Shipping is performed according to identification code and marks on the transportation packing.

4.3 Fasten the packing and transport it according to the established rules and specifications of the relevant transport.

4.4 When moving in the hunting field, carry the rifle in the slung position. Adjust the sling to avoid impacts of the rifle with hard surfaces of your equipment at walking. Carry the rifle with the magazine attached and the safety engaged.

5 STORAGE

5.1 To maintain in good operating order, keep the rifle cased, whenever possible, always cleaned and lubricated with a thin layer of the rifle oil. The case must be clean and dry.

5.2 Store the rifle in dry premises without sharp temperature changes, far from heating devices and without aggressive substances in the ambient air.

5.3 Store the rifle always unloaded, with the magazine detached, safety engaged and the hammer released to avoid permanent deformation of the mainspring.

6 COMPLETE SET

6.1 The complete set of the rifle is given in **Table 6.1**

Table 6.1

Designation	Description	Qty, pcs
ИЖ-151.С60	SR1 autoloading hunting rifle	1
ИЖ-151.С62-2	Ambidextrous charging handle	1
МАГАЗИН калибра 223 Rem.	Magazine	2
ИЖ-151.3-4	Return spring	2
ИЖ-151.4-3	Rack spring	2
ИЖ-151.0-7	Left safety	1
Set of mounting parts		
ИЖ-151.С68	Swivel assembly	1
ИЖ-151.С69	Rail assembly	1

Designation	Description	Qty, pcs
Set of tools and accessories		
СОК-Ю-АК.1-01	Cleaning rod	1
	Allen wrench	1
МКС-К.С619	Single set of accessories	1
Operating documents		
ИЖ-151 РЭ	SR1 autoloading hunting rifle, Service Manual	1
ИЖ-151 ПС	SR1 Autoloading hunting rifle, Certificate	1
Packing		
	Polymer package (case and insert)	1



APPENDIX A (normative)

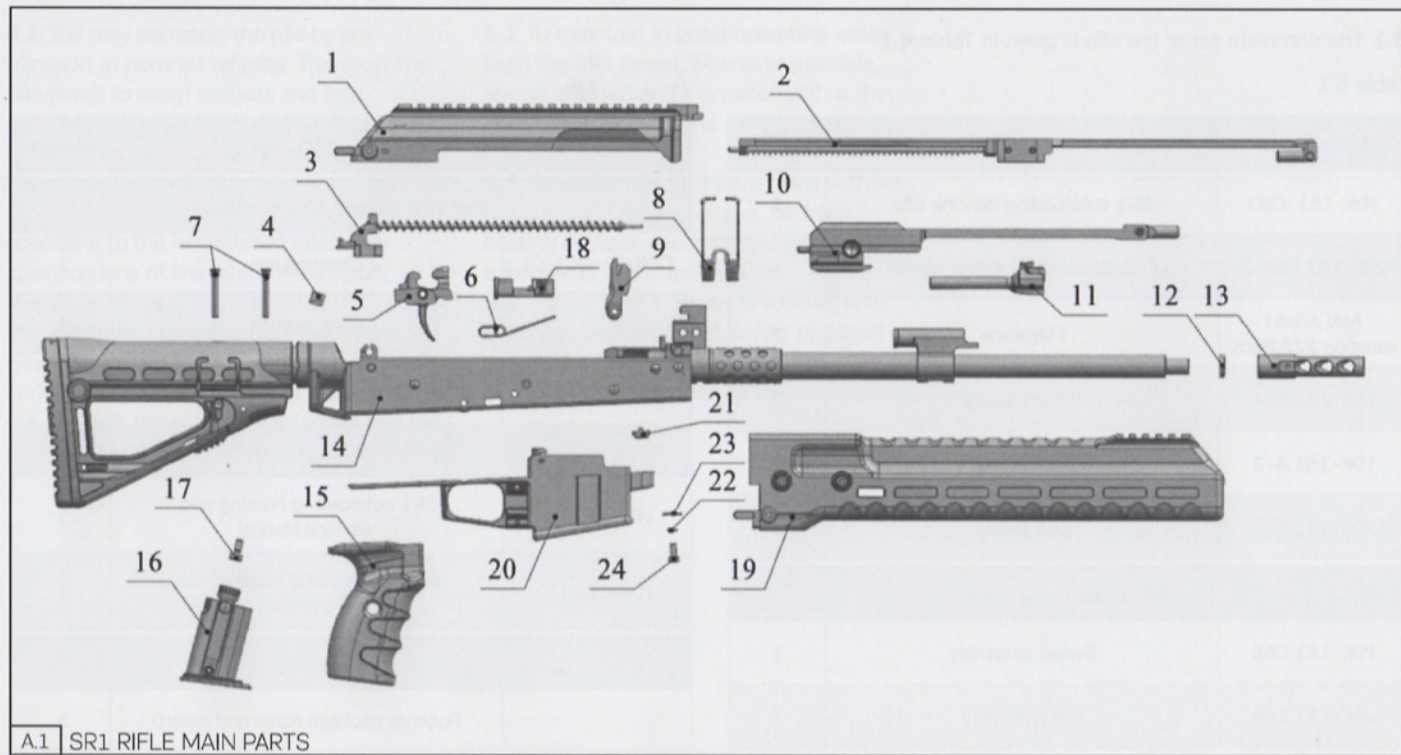

A.1 SR1 RIFLE MAIN PARTS



A.1 The list of the SR1 main parts is given in Table A.1

Table A.1

Item No. as shown in Fig. A.1	Part Name
1	Receiver cover assembly
2	Rack assembly
3	Retracting mechanism
4	Nut
5	Trigger mechanism
6	Trigger-mechanism spring
7	Trigger-mechanism pin (2 pcs)
8	Mainspring
9	Hammer
10	Bolt carrier assembly
11	Bolt assembly
12	Washer
13	Muzzle brake

Item No. as shown in Fig. A.1	Part Name
14	Receiver, barrel and buttstock assembly
15	Pistol grip
16	Container
17	Screw
18	Safety
19	Fore-end assembly
20	Magwell assembly
21	Nut
22	Washer
23	Washer
24	Screw



APPENDIX B (normative)

© 2011 Kongsberg Gruppen AS. All rights reserved. Kongsberg Gruppen AS is not responsible for any damage or injury caused by the use of the information in this document.

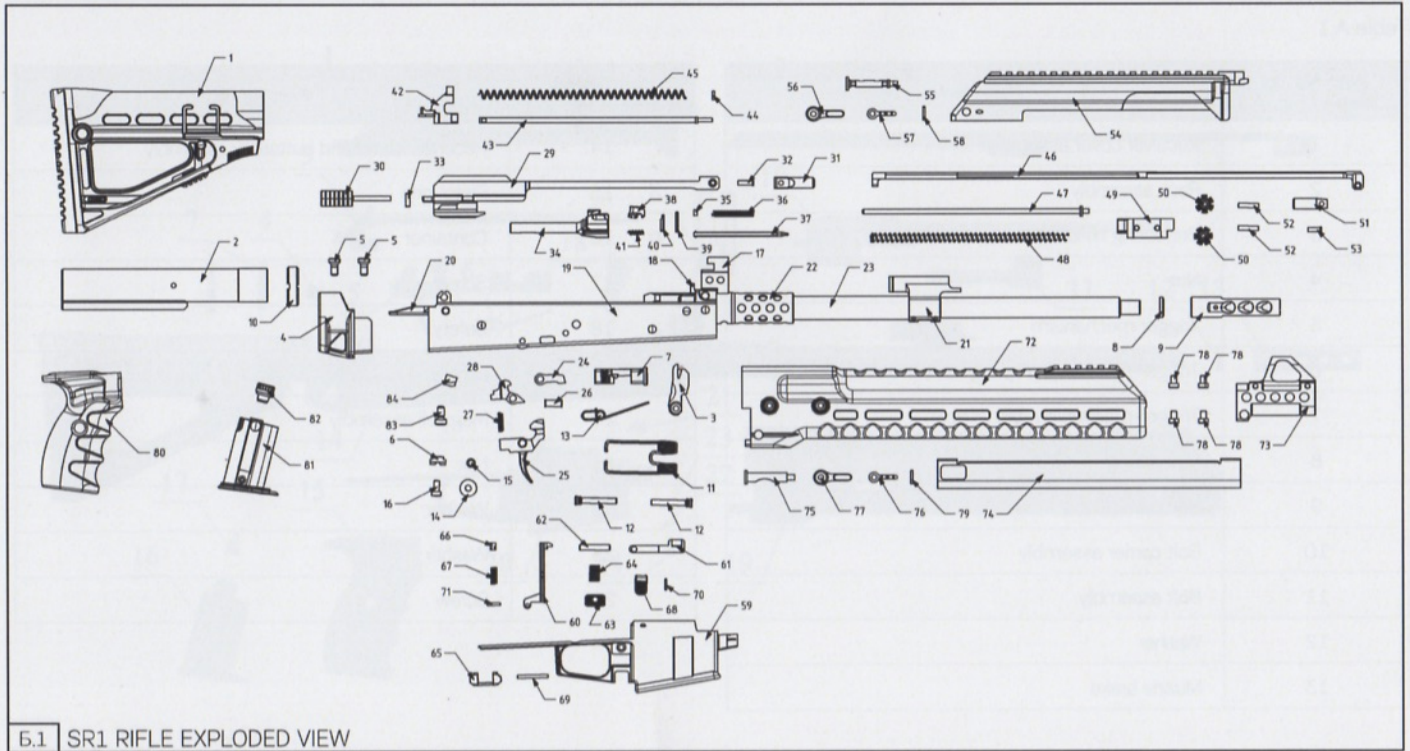

B.1 SR1 RIFLE EXPLODED VIEW



B.1 The list of the SR1 assembly units and parts is given in Table B.1

Table B.1

No.	Designation	Name	Item Number
1		Buttstock	
2		Buttstock tube	
3	ИЖ-151.0-1	Hammer	132400901011
4	ИЖ-151.0-3	Adapter	132400903041
5	ИЖ-151.0-4	Screw	132400904031
6	ИЖ-151.0-5	Magwell nut	132400905031
7	ИЖ-151.0-6	Right safety	132400906051
8	ИЖ-151.0-8	Washer	132400908081
9	ИЖ-151.0-9	Muzzle brake	132400909021
10	ИЖ-151.0-10	Adapter nut	132400910011
11	СОК-12.40-43	Mainspring	499100940431
12	СОК-АК0-25	Trigger-mechanism pin	107200901511
13	СК-308.0-6	Trigger-mechanism spring	201400906061
14		Washer	499500924681
15		Washer	499500924691
16		Screw	499500927701
17	ИЖ-151.1-3	Support	132400901031
18	ИЖ-151.1-4	Hole	132400901041
19	ИЖ-151.1-1	Receiver	132400901021
20	ИЖ-151.1-6	Butt-plate	132400901061
21	ИЖ-151.1-8	Gas block	132400901081
22	ИЖ-151.1-7	Fore-end base	132400901071

No.	Designation	Name	Item Number
23	ИЖ-151.1-12	Barrel	132400901121
24	ИЖ-151.0-2	Hammer limiter	132400902051
25	СОК-12С.2-1-01	Trigger	207300902011
26	СОК-АК0-27	Bush	107200900271
27	СОК-АК0-10	Sear spring	107200901601
28	СОК-АК0-45	Sear	107200945011
29	ИЖ-151.2-1	Bolt carrier	132400902011
30	ИЖ-151.2-2	Charging handle	132400902021
31	ИЖ-151.2-3	Carrier piston	132400902031
32	ИЖ-151.2-4	Piston pin	132400902041
33		Pin	499500924711
34	СОК-223.3-4	Bolt	480400901261
35	СОК-223.3-12	Bush	480400903031
36	СОК-223.3-13	Firing-pin spring	480400903041
37	СОК-АК.3-5-01	Firing pin	107200901751
38	СОК-223.3-11	Extractor	480400901361
39	СОК-АК.3-9	Firing-pin stud	107200901881
40	СОК-АК.3-10	Extractor pin	107200901771
41	СОК-АК.3-7	Extractor spring	107200907011
42	ИЖ-151.3-1	Base	132400903011
43	ИЖ-151.3-2	Guide	132400903021
44	ИЖ-151.3-3	Washer	132400903031



No.	Designation	Name	Item Number
45	ИЖ-151.3-4	Return spring	132400900131
46	ИЖ-151.4-1	Rack	132400904011
47	ИЖ-151.4-2	Guide	132400904021
48	ИЖ-151.4-3	Rack spring	132400900141
49	ИЖ-151.4-4	Carriage	132400904041
50	ИЖ-151.4-5	Sprocket	132400904051
51	ИЖ-151.4-6	Rack piston	132400904061
52	ИЖ-151.4-7	Sprocket pin	132400904071
53	ИЖ-151.4-8	Piston pin	132400904081
54	ИЖ-151.C65-1	Receiver cover	132400905021
55	ИЖ-151.5-4	Cover lock	132400905041
56	ИЖ-151.5-5	Lock handle	132400905051
57	ИЖ-151.5-6	Lock spring	132400905061
58		Pin	
59	ИЖ-151.C66-1	Magwell	132400906031
60	ИЖ-151.C66-2	Bolt stop	132400906021
61	ИЖ-151.6-4	Latch	132400906141
62	ИЖ-151.6-6	Latch pin	132400906061
63	ИЖ-151.6-7	Button	132400906071
64	ИЖ-151.6-8	Latch spring	132400906081
65	ИЖ-151.6-11	Bolt-stop button	132400906011
66	ИЖ-151.6-13	Plug	132400906131
67	ИЖ-151.6-12	Bolt-stop spring	132400906041
68	ИЖ-151.6-14	Button	499500924721
69		Pin	499500924731

No.	Designation	Name	Item Number
70		Pin	499500924741
71		Screw	132400907111
72	ИЖ-151.C67-1	Fore-end	132400907051
73	ИЖ-151.7-5	Fore-end insert	132400907041
74	ИЖ-151.7-4	Shield	132400907061
75	ИЖ-151.7-6	Fore-end lock	132400905061
76	ИЖ-151.5-6	Lock spring	132400905051
77	ИЖ-151.5-5	Lock handle	132400907031
78	ИЖ-151.7-7	Fore-end screw	
79		Pin	135700900091
80	МКК-К.C69	Pistol grip	135700912011
81	МКК-К.12-1	Container body	135700912031
82	МКК-К.12-3	Container rivet	135700918071
83	МКК-К.18-1	Grip screw	135700918081
84	МКК-К.18-2	Nut	132400906121
Set of mounting and replacement parts			
	ИЖ-151.C62-2	Ambidextrous handle	132400900151
	ИЖ-151.0-7	Left safety	132400907001
	ИЖ-151.8-1	Swivel	132400908011
	ИЖ-151.8-2	Bush	132400908021
		Screw	499500924751
	ИЖ-151.9-1	Rail	132400909011

JSC "CONCERN "KALASHNIKOV"
PROYEZD IM. DERYABINA, 3
IZHEVSK, UDMURT REPUBLIC 426006
RUSSIA
TEL./FAX: + 7 (3412) 51-22-25

WWW.KALASHNIKOV.COM

