

AK



SEMI-AUTOMATIC HUNTING CARBINE

MR1

In 7.62x54R

SERVICE MANUAL

CONTENTS

Introduction	4
1 Description and operation	5
2 Use for designated purpose	8
3 Maintenance	12
4 Storage	18
5 Transportation	19
6 Complete set	19
7 Acceptance certificate	20



IMPORTANT! BEFORE USING THE CARBINE, FOR YOUR SAFETY AND THE SAFETY OF OTHERS READ CAREFULLY AND UNDERSTAND THIS SERVICE MANUAL PAYING SPECIAL ATTENTION TO THE FIREARM SAFETY RULES AND PRECAUTIONS.

This Service Manual (hereinafter in the text referred as the Manual) contains the information for the correct and safe use of the MR1 semi-automatic hunting carbine in 7.62x54R.

The MR1 semi-automatic hunting carbine in 7.62x54R (hereinafter in the text referred as the carbine) comes in different versions, as follows:

- MR1 (ИЖК-173.C6) – with folding telescopic buttstock;
- MR1 version 01 (ИЖК-173.C6-01) – with fixed (non-folding) telescopic buttstock.

The information on the optical sight is given in its certificate (if the sight is delivered with the carbine).

The carbine design provides its safe functioning if observing requirements of the Manual.

Some minor design alterations may be not included in the Manual since the carbine is under constant improvement.

1 DESCRIPTION AND OPERATION

1.1 Purpose of carbine

The MR1 semi-automatic hunting carbine in 7.62x54R is intended for hunting as well as shooting sports.

The general view of the carbine is shown in **Figure 1.1**

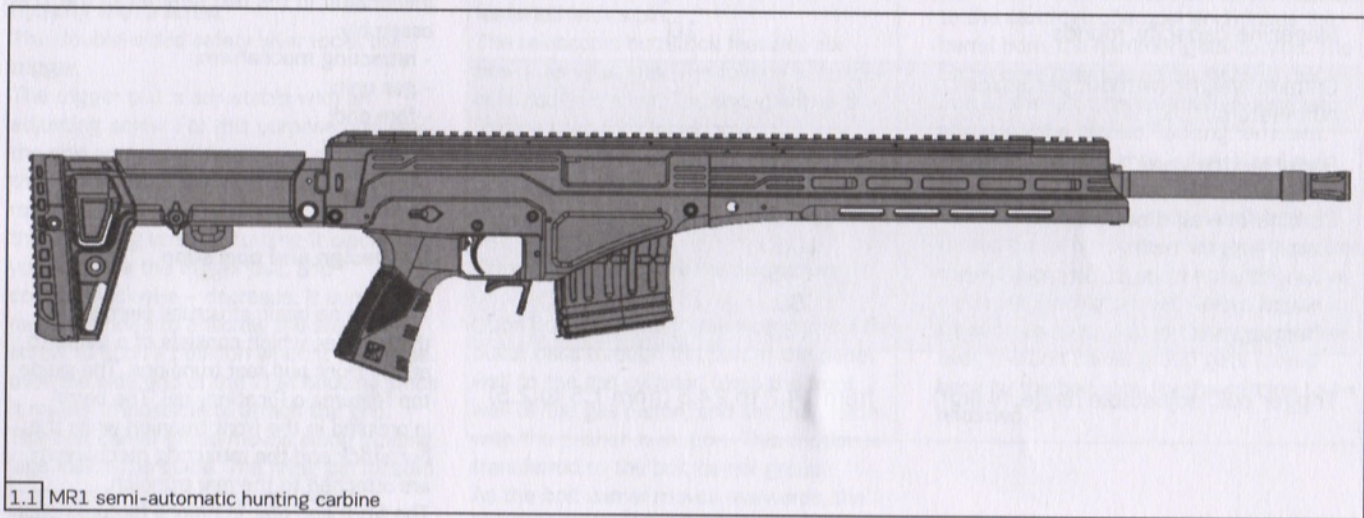

1.1 MR1 semi-automatic hunting carbine

1.2 Specifications

The carbine specifications are given in Table 1.

Table 1.

Parameter	Value	
	MR1	MR1 ver.01
Magazine capacity, rounds	10	
Carbine weight (without parts from complete set), kg	4.5	4.3
Barrel length, mm	530	410
Carbine overall dimensions:		
- total length, mm	1050	930
- length with folded buttstock, mm	845	-
- width, mm	80	80
- height, mm	180	190
Trigger pull, adjustable range, N (kgf)	from 14.7 to 24.5 (from 1.5 to 2.5)	

1.3 Carbine set

The carbine consists of the following main parts and components:

- receiver and barrel assembly;
- bolt carrier;
- bolt assembly;
- housing of trigger-and-firing mechanism (hereinafter in the text referred as the TFM) assembly;
- retracting mechanism;
- gas unit;
- fore end;
- buttstock;
- flash suppressor;
- magazine.

1.4 Design and operation

The carbine basic structural element is the receiver, which consists of a guide to attach front and rear trunnions. The guide top features a Picatinny rail. The barrel is pressed in the front trunnion while the buttstock and the retracting mechanism are attached to the rear trunnion.

The front and rear trunnions feature holes

to mount the TFM housing.

The TFM aluminum-alloy housing is attached with two pins. The housing incorporates the trigger-and-firing mechanism, safety lever, bolt stop, and the magazine latch. The housing bottom features a magazine well and a trigger guard. The control grip is attached to the housing with a screw.

The double-sided safety lever locks the trigger.

The trigger pull is adjustable with an adjusting screw. For this purpose unscrew the grip screw and detach the grip with the washer from the TFM housing. The rear end of the TFM housing comprises the adjusting screw. If turning it clockwise, you increase the trigger pull, and counterclockwise – decrease. It is not recommended to unscrew the adjusting screw to such a position when it protrudes over the side end of the TFM housing since it makes impossible to attach the grip. The bolt carrier group moves along guiding lugs inside the guide. The firing pin located in the bolt channel is spring-loaded. The retracting mechanism consists of a

rear insert, bush, rod, and two springs.

The gas unit includes a gas cylinder, regulator, gas piston, pusher, and a pusher spring. The gas cylinder is pressed on the barrel; the pusher and the spring are located in the guide seat.

The front portion of the fore end rests on the guide lugs, and its rear portion is fastened with a pin.

The telescopic buttstock features six positions by length. The folding buttstock is folded to the left. The end-piece of the folding buttstock includes a spring-loaded retainer.

The barrel muzzle portion features the right M18x1 thread to accept muzzle devices.

Principle of the carbine operation:

Upon firing, powder gases from behind the bullet pass through the port in the barrel wall to the gas cylinder, force the front wall of the gas piston, and set the piston with the pusher in motion. This motion is transferred to the bolt carrier group. As the bolt carrier moves rearwards, the bolt rotates, unlocks the barrel bore, and

then extracts the cartridge case from the cartridge chamber, and the ejector expels it from the receiver; the bolt carrier compresses the return spring and cocks the hammer (sets it at the lever). While the retracting mechanism forces the bolt carrier group to the front, the bolt feeds the next cartridge from the magazine to the cartridge chamber and closes the barrel bore; the hammer gets cocked. The barrel bore gets locked by rotating the bolt to the left with its three locking lugs engaging the receiver locking recesses. To make the next shot, release and pull the trigger. The trigger shaped lug releases the hammer. The hammer, while being turned on its pin by the mainspring, strikes the firing pin, which in its turn strikes the cartridge igniting primer. A shot is fired. As soon as all rounds in the magazine are over, the bolt carrier group gets locked back by the bolt stop for the carbine to be reloaded.

1.5 Marking

The carbine receiver is marked with the carbine model name and serial number, trademark of the manufacturing plant, cartridge designation as well as the following special marks:



proof mark of the C.I.P. (Permanent International Commission for the Proof of Small Arms) accredited Proof House (PH) and carbine proofing year (two last digits of the year under the proof mark);



The PH proof mark is additionally imprinted on the barrel and the bolt;

CIP
N

standard proof mark of the C.I.P.

2 USE FOR DESIGNATED PURPOSE

2.1 General

Before using the carbine, carefully read this Manual and understand the carbine design and mechanics. Pay special attention to the safety precautions.

To prepare the carbine for use, remove the packaging from the carbine, tools and accessories, remove protective grease, check the complete set and make sure the carbine is serviceable.

Dispose of the packaging paper and film since they are toxic.

2.2 To prepare carbine for use

2.2.1 Safety precautions while preparing carbine

The carbine design provides its safe functioning if observing operational rules and using 7.62x54R relevant ammunition. Since ballistics of cartridges from different manufacturers differ, make sure to select those cartridges that suit your carbine best

by providing its reliable operation and meet your quality requirements.

2.2.2 Procedure to prepare carbine for use

Use the following procedure to prepare the carbine:

- wipe the bore and the chamber dry from grease and fouling;
- attach the optical sight to the carbine;
- check the operation of the trigger mechanism and safety lever;
- check the carbine proper functioning, for this purpose retract the bolt carrier group with its handle rearward to the stop and release it. Make a control dry fire by pressing the trigger.

The carbine is ready for use.

2.3 To use carbine

2.3.1 Procedure to use carbine

To engage/disengage the safety lever:

- to engage the safety - shift the safety

lever up to the safety position, as shown in **Figure A.1**. The trigger is blocked;

- to disengage the safety - shift the safety lever down to the fire position, as shown in **Figure A.2**.

Loading and firing procedure:

Use the following procedure to load the carbine:

- attach the loaded magazine into the magazine well of the TFM housing and make sure it is fixed with the latch;
- disengage the safety;
- pull the bolt carrier group with the charging handle to the fully rearward position, as shown in **Figure A.3**, and release it.

The carbine is ready for firing.

To make a shot, aim and press the trigger.

The shot is fired. For the next shot, release the trigger and press it anew.

IMPORTANT! IN CASE OF A STOPPAGE DUE TO THE CARTRIDGE CASE GOT STUCK AFTER THE SHOT, MAKE SURE TO SWITCH THE REGULATOR FROM POSITION '1' TO POSITION '2'.

2.3.2 Safety precautions while using carbine for designated purpose



REMEMBER! THE MAIN PURPOSE OF THE SAFETY PRECAUTIONS LAID DOWN IN THIS MANUAL IS TO MAKE AN APPEAL TO FIREARM OWNERS FOR CAREFUL HANDLING WITH THEIR FIREARMS AND TO REMIND THAT THE RESPONSIBILITY FOR THE FIREARM USE RESTS WITH THOSE WHO OWN IT AND USE IT.

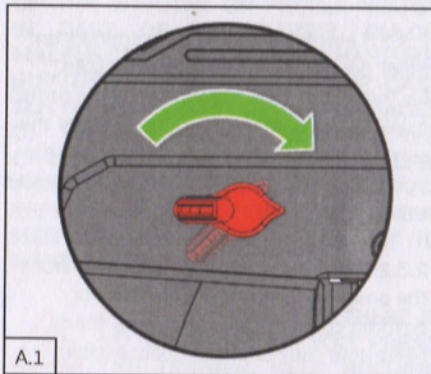

A.1

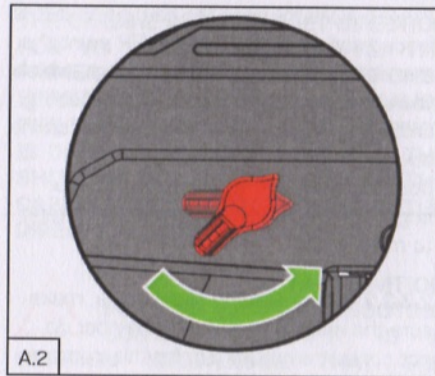

A.2

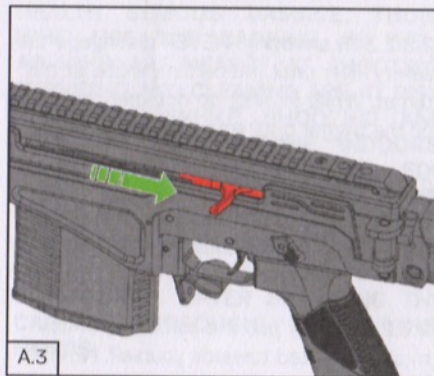

A.3



2.3.2.1 ALWAYS treat the carbine as if it is loaded and ready for fire. NEVER point the muzzle to people, animals or things, which you are not going to fire at. When loading, unloading, servicing or cleaning the carbine, always make sure to keep the muzzle pointed to the SAFE direction. Put your finger on the trigger only when you intend to make a shot.

2.3.2.2 Before loading the carbine, make sure the magazine and the chamber do not contain ammunition, for this purpose retract the bolt to the rear.

2.3.2.3 At shooting, NEVER disengage the safety lever until the carbine is laid at the target. While aiming, do not keep your finger on the trigger until you are ready to fire.

2.3.2.4 When shifting the safety lever, make sure it is completely fixed. ALWAYS remember that the half-engaged safety selector is NOT ENGAGED!

2.3.2.5 NEVER pull the carbine with its muzzle directed towards yourself. NEVER

put your hand on the muzzle and NEVER rest upon the carbine.

2.3.2.6 NEVER leave the carbine so that it could fall and make a fire.

2.3.2.7 You should always be aware of the direction you are shooting at and what is located behind the target. Before the shot, ask yourself what the bullet hits if it goes right through or misses the target. NEVER shoot at hard surfaces or water due to the possible ricochet that changes the bullet trajectory into hardly predictable.

2.3.2.8 Having received the carbine from other person, NEVER take for granted his/her words that the carbine is unloaded. ALWAYS make sure of it yourself – for this purpose detach the magazine, retract the bolt and inspect that the cartridge chamber is empty.

2.3.2.9 Store the carbine separately from the ammunition so that strangers or children could not get access to them. Make sure they are really inaccessible.

When outside the storage place, NEVER leave the carbine unattended.

2.3.2.10 Before any operations with the carbine (disassembly, cleaning etc.), MAKE SURE it is unloaded. ALWAYS store and transport the carbine unloaded.

2.3.2.11 ALWAYS unload the carbine before entering any building or tent, getting on a vehicle or boat. NEVER load or unload the carbine inside the vehicle or building (except an indoors shooting range).

2.3.2.12 While unloading the carbine, make sure to inspect the chamber after detaching the magazine.

2.3.2.13 IT IS PROHIBITED to use the carbine while intoxicated. NEVER take alcohol or drugs before or during the shooting.

2.3.2.14 NEVER try to 'improve' the carbine. Do not try to remove the safety lever or any internal safety mechanism or element since it may cause an accidental

discharge.

2.3.2.15 At shooting, IT IS STRONGLY RECOMMENDED to use ear protection and shooting glasses.

2.3.2.16 For shooting, use cartridges corresponding to the marking imprinted on the carbine.

2.3.2.17 Do not use for shooting damaged, reusable or undesignated cartridges. It is prohibited to change the powder load weight of factory cartridges and to change the bullet weight. Always make sure to use only clean and dry factory-loaded ammunition.

2.3.2.18 Do not fire cartridges after termination of their expiry date specified on the packing.

2.3.2.19 Before loading, visually inspect the barrel bore for the absence of snow, dirt, mud, or litter.

2.3.2.20 If the sound of the shot is much different from the previous ones, immediately stop using the carbine. Unload

the carbine and visually inspect the barrel, receiver, and all other parts.

In case the cartridge components get stuck in the barrel bore, first make sure to remove them. If there is something inside the barrel bore, NEVER try to remove this by shooting with another cartridge, even if it is blank or without the bullet.



REMEMBER! THE FAILURE TO COMPLY WITH REQUIREMENTS SPECIFIED IN PARAGRAPHS 2.16 – 2.20 MAY CAUSE THE DAMAGE OF THE BARREL AND SERIOUS INJURIES OF THE SHOOTER OR PEOPLE NEARBY. IN CASE OF THE BARREL BULGE, MALFUNCTION OF THE MECHANISMS, RUPTURES OF THE CARTRIDGE CASE BOTTOM, OR ANY OTHER DAMAGES OF THE CARBINE PARTS, HAVE THE CARBINE SENT TO THE SPECIALIZED WORKSHOP FOR DIAGNOSTICS AND REPAIR. IN CASE OF THE ABOVE MENTIONED DEFECTS, NEVER TRY TO MAKE ONE MORE SHOT.



IMPORTANT! IN CASE THERE IS NO SHOT AFTER YOU PRESS THE TRIGGER, KEEP HOLDING

THE CARBINE IN THE TARGET DIRECTION FOR AT LEAST ONE MINUTE. THE PRIMER MAY HAVE A SLOW RESPONSE SOMETIMES, AND THAT MAY CAUSE THE "HANG FIRE". I.E. WHEN THE SHOT IS DISCHARGED WITH A DELAY. IF THE SHOT DID NOT HAPPEN, UNLOAD THE CARBINE HOLDING THE BARREL IN THE DIRECTION SAFE FOR SHOOTING.



IMPORTANT! AMMUNITION FOR THE CARBINE SHOOTING CONTAIN LEAD. IT IS A COMMON KNOWLEDGE THAT THE LEAD PENETRATION MAY CAUSE HEALTH SERIOUS DAMAGE. THOSE WHO USE THE CARBINE AS WELL AS WHO ARE NEARBY AT SHOOTING, SERVICING AND CLEANING ARE AT RISK. THEREFORE, WHILE SHOOTING AND CLEANING THE CARBINE INDOORS, MAKE SURE TO PROVIDE FOR THE PROPER VENTILATION. WHEN CLEANING THE CARBINE, UNDERTAKE PROTECTIVE MEASURES TO AVOID CONTACT WITH THE LEAD AND ITS COMPOUNDS. AFTER SERVICING THE CARBINE, THOROUGHLY WASH YOUR HANDS.

2.3.2.21 Cracks on fired cases that may appear farther than 5 mm from the extractor groove, on the case neck and shoulder providing that the powder gases do not escape between the case body and the chamber first cone, do not mean the carbine is defective since the cartridge specifications allow for such cracks on the fired cases.

IMPORTANT! IT IS STRICTLY PROHIBITED TO USE CARTRIDGES OF IRRELEVANT CALIBER!

Remember that the use of hand-loaded, expired, corroded, or undesignated ammunition may result in the carbine destruction due to the dangerously high pressure of powder gases. To avoid breaking of the TFM, it is not recommended to dry fire. In case of the carbine breakdown (destruction of main parts) that results from the nonobservance by the User of the safety precautions laid down in the present Section, the manufacturing plant bears no responsibility.

3 MAINTENANCE

3.1 Field stripping

Perform the field stripping to inspect the carbine and to clean and lubricate it after each shooting.

Field stripping procedure:

- detach the magazine. Holding the magazine with your hand, press the magazine latch, bring the magazine lower portion to the front, and detach the magazine, as shown in **Figure A.4**;
- check for the absence of the cartridge in the cartridge chamber. For this purpose disengage the safety lever by shifting it down, retract the bolt carrier group with its handle to the rear, visually inspect the chamber, and release the handle, as shown in **Figure A.5**;
- if necessary, detach the optical sight using required tools;

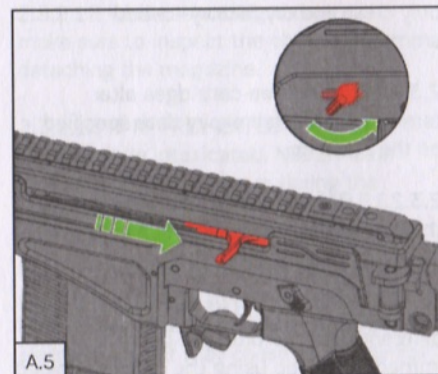
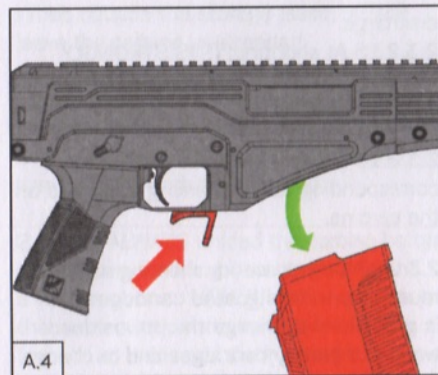



WARNING: THE NEXT OPERATIONS FOR THE CARBINE DISASSEMBLY SHOULD BE PERFORMED ONLY WITH THE HAMMER COCKED. FOR THIS PURPOSE RETRACT THE BOLT CARRIER GROUP WITH ITS HANDLE TO THE REAR UNTIL THE HAMMER SETS AT THE LEVER.

- for the convenience in further disassembly, turn the carbine with its control grip up;
- press the heads of the pins that fasten the TFM housing and force the pins out to the stop. Detach the TFM housing by moving upwards, as shown in **Figure A.6**;
- detach the retracting mechanism. First bring the retracting mechanism up, then back and extract it from the guide rear trunnion, as shown in **Figure A.7**;
- detach the bolt carrier group. Retract the bolt carrier with its handle backwards to the stop, bring it up, and detach it from the guide, as shown in **Figure A.8**;
- detach the bolt from the bolt carrier. Turn the bolt to disengage the bolt lug from the shaped slot of the bolt carrier, then advance the bolt to the front, as shown in **Figure A.9**;

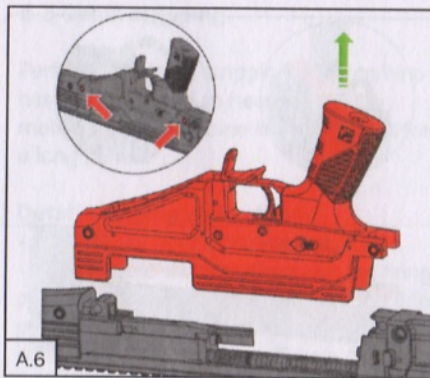

A.6

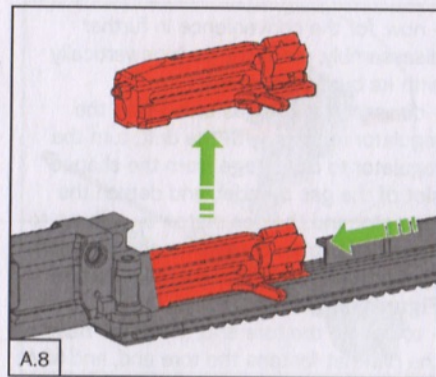

A.8

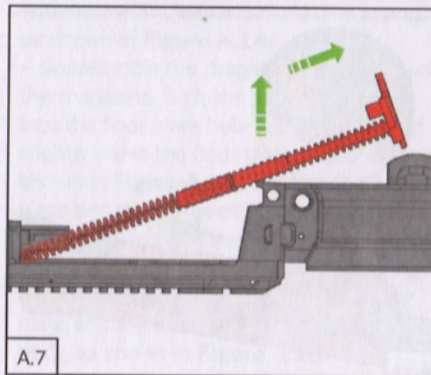

A.7

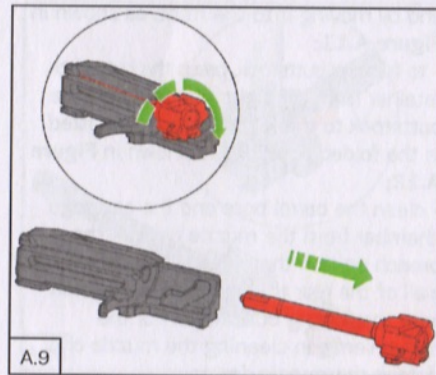

A.9

- now, for the convenience in further disassembly, place the carbine vertically with its buttstock down;
- disassemble the gas unit. Press the regulator retainer with the drift, turn the regulator to disengage from the shaped slot of the gas cylinder, and detach the regulator and the gas piston by moving to the front. Extract the pusher and the pusher spring from the guide seat, as shown in **Figure A.10**;
- to detach the fore end, press the head of the pin that fastens the fore end, and force the pin out to the stop. Detach the fore end by moving it to the front, as shown in **Figure A.11**;
- to fold the buttstock, press the buttstock retainer from the right side and turn the buttstock to the left so that it gets fixed in the folded position, as shown in **Figure A.12**;
- clean the barrel bore and the cartridge chamber from the muzzle or from the breech portion through the hole in the back wall of the rear trunnion (for the version with the folding buttstock). For the convenience in cleaning the muzzle end, detach the muzzle device.

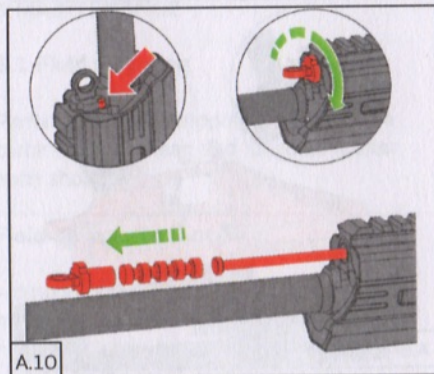

A.10

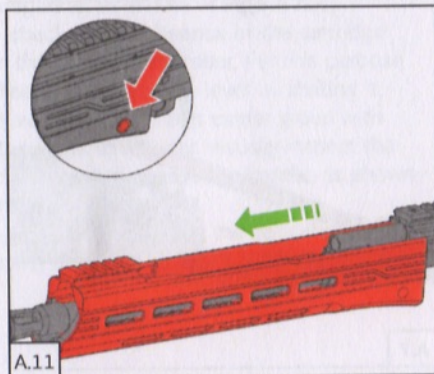

A.11

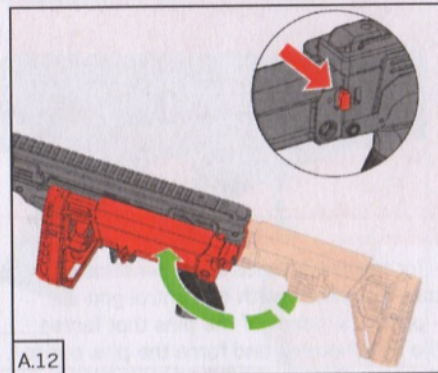

A.12

3.2 To reassemble after field stripping

Reassembly procedure:

- unfold the buttstock and turn it until it is fixed (for the version with the folding buttstock);
- mount the fore end. Put the fore end on the barrel, shift it to the back, and engage the fore end lugs into the guide relevant slots. Fix the fore end by pressing the pin head and forcing the pin in to the stop;
- reassemble the gas unit. Place the carbine vertically with its buttstock down.

Bring the pusher with the spring and the piston into the guide seat. Then insert the regulator into the guide seat, push the piston down, sink the regulator and turn it until it is fixed with the plunger;

- attach the bolt to the bolt carrier. Insert the bolt into the carrier and turn the bolt so that its guiding lug engages with the carrier shaped slot. Advance the bolt to the front;
- place the carbine horizontally with the Picatinny rail down. Insert the bolt carrier group into the guide relevant slots and advance the carrier to the front;
- bring the front end of the retracting mechanism spring into the bolt carrier and insert the retracting mechanism down into the slot of the rear trunnion;



IMPORTANT! MOUNT THE TFM HOUSING ONLY WITH THE HAMMER COCKED.

- mount the TFM housing. Fix it by pressing the pins to the stop;
- attach the magazine. Bring the magazine front hook into the TFM well and turn it until its rear hook is fixed with the latch.

3.3 Detail stripping

Perform the detail stripping if the carbine has been exposed to heavy mud, dirt, moisture or the carbine is to be stored for a long period.

Detail stripping procedure:

- perform the field stripping;
- disassemble the bolt. Drive out the firing pin stud with the drift and remove the firing pin with the spring and the bush from the bolt channel, as shown in **Figure A.13**;
- force out the extractor pin with the drift and remove the extractor with the spring, as shown in **Figure A.14**;
- disassemble the magazine. First, unload the magazine. Sink the locking plate lug into the floor plate hole with the drift and slightly move the floor plate to the front, as shown in **Figure A.15**. Holding the locking plate and thus preventing the spring from expanding, remove the floor plate from the magazine body. Slowly release the spring and take it out together with the locking plate and the follower from the magazine body, as shown in **Figure A.16**.

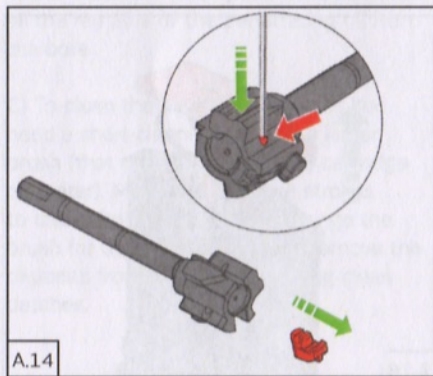
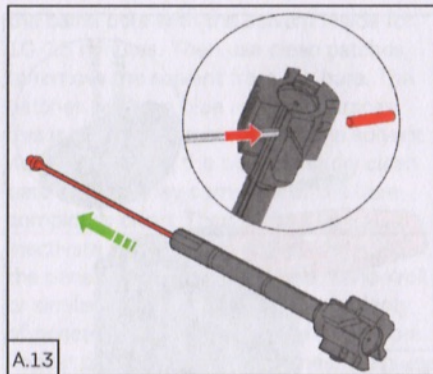

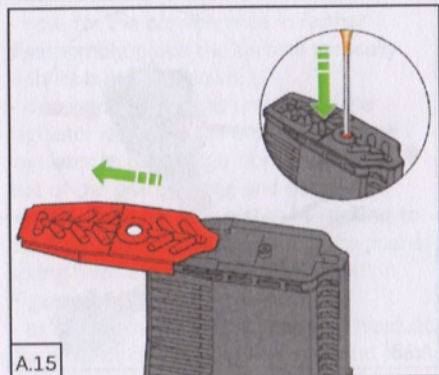

A.15

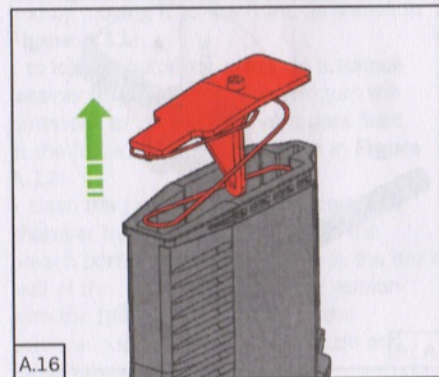

A.16



IMPORTANT! THE DISASSEMBLY AND REASSEMBLY OF THE RETRACTING MECHANISM AND TRIGGER-AND-FIRING MECHANISM WITH THE SAFETY LEVER SHOULD BE PERFORMED ONLY IN THE SPECIALIZED REPAIR CENTER!

3.4 To reassemble after detail stripping

Reassembly procedure:

- reassemble the magazine. For this purpose attach the magazine spring to the follower and the locking plate and place the follower into the magazine body. Compress the spring so that the locking plate is fully inside the body and move the floor plate on the body lugs. Move the floor plate to the back until the locking plate lug is retained in the floor plate hole;
- reassemble the bolt. For this purpose place the extractor with the spring into the bolt and fix it with the pin. Insert the firing pin with the spring into the bolt channel and fix it with the stud. Make sure the extractor pin and the firing pin stud do not protrude over the bolt body;
- perform further reassembly operations as specified in Section 3.2.

3.5 Cleaning and lubrication

Clean the carbine within one day after shooting. In winter clean the carbine indoors at temperature $(20 \pm 5) ^\circ\text{C}$ after the carbine has warmed up to the indoor temperature. For cleaning, use a clean cloth (rag, tow) without sand or any hard particles.

Clean the barrel bore after the field stripping, with the buttstock folded and from the breech portion through the hole in the back wall of the rear trunnion; as for the carbines with the non-folding buttstock, clean the barrel bore from the muzzle with the muzzle device detached.

Cleaning procedure:

- perform the field stripping;
- clean the barrel bore;
- remove the fouling and dirt from the bolt recess bottom and bolt slots;
- remove dirt from the receiver.

For cleaning, we recommend to place the carbine into a specialized support.

A) To remove the fouling from the barrel bore. For this purpose you need a cleaning

rod and a brush of required size (caliber) and a special solvent (for example, Butch's Bore Shine or similar). Insert the cleaning rod with the screwed brush into the barrel bore from the muzzle or fold the buttstock and from the hole in the back wall of the rear trunnion (for the version with the folding buttstock) and push it to the front until the brush is out of the barrel bore opposite completely. Moisten the brush with plenty of solvent (we recommend bronze or brass brushes). Make 8-10 back-and-forth travels of the brush inside the barrel bore, each cycle make sure that the brush goes out completely from the muzzle and into the chamber. After 8-10 strokes take the brush out from the muzzle and again moisten it with plenty of solvent. Then repeat the cleaning cycle (8-10 back-and-forth strokes). After that, detach the brush (make sure to wash it with water, otherwise the solvent will damage the brush within some time). Screw the pull-through (jag) on the cleaning rod. Using the jag (bronze or aluminium) and the wiping material (patch) (make sure it is dry and clean), completely remove the fouling and the solvent deposits

from the barrel bore (each patch should be used only one time). For this purpose, fix the patch on the jag and push it into the barrel bore from the cartridge chamber. As soon as the patches coming out of the barrel are clean, make sure to inactivate the solvent remains. For this, you need a penetrating oil (for example, Kano Kroil or similar). Moisten the patch with plenty of penetrating oil and wipe the barrel bore. Repeat the operation three times. Then use two or three dry clean patches to remove the remains of the penetrating oil from the bore.

B) To remove copper traces. If after the cleaning stage A you see copper traces from bullet jackets (for example, when you visually inspect the bore muzzle end), you should perform decopperizing. You need a cleaning rod with a jag and a copper removal solvent (for example, Shooter Choice Copper Remover or similar). Fix the patch on the jag, moisten it with plenty of copper removal solvent, and bring it into the barrel bore. Repeat the operation two or three times. Leave

the barrel bore with the solvent inside for 10-15 minutes. Then use clean patches to remove the solvent from the bore. The patches will have blue and green traces: this is the copper reacted with the solvent. Keep on cleaning the bore using dry clean patches until they come out of the bore completely clean. Then make sure to inactivate the solvent remains. You need the penetrating oil (for example, Kano Kroil or similar). Moisten the patch with plenty of penetrating oil and wipe the barrel bore. Repeat the operation three times. Then use two or three dry clean patches to remove all the remains of the penetrating oil from the bore.

C) To clean the cartridge chamber. You need a short cleaning rod and a larger brush (that slightly exceeds the cartridge diameter). Make 8-10 double strokes to clean the chamber. Then change the brush for the pull-through and remove the deposits from the chamber using clean patches.



D) To lubricate the barrel bore and cartridge chamber. The cleaning procedure for the barrel bore and cartridge chamber finishes with their lubrication. You need a short and a long cleaning rods, jags, patches, and the Kalashnikov gun oil (or similar). Moisten a patch with the moderate quantity of the oil and wipe the barrel bore one time, then take another patch and the short cleaning rod and wipe the cartridge chamber.

E) To clean the receiver. You need several clean pieces of cloth and the Kalashnikov gun degreaser. Moisten a piece of cloth with the degreaser and remove the fouling and dirt. Use a wooden or plastic stick or a hook to clean hard-to-reach places. Then, we recommend to apply the Kalashnikov ceramic grease to the TFM, bolt, and the receiver inner surface and to wipe other metal parts with a piece of cloth moistened with the Kalashnikov gun oil. Before shooting, you should wipe dry the barrel bore and the cartridge chamber (better to use the Kalashnikov gun degreaser, otherwise the MPI of the first one or two shots may be significantly

deviated!).

Remember that the solvents are high-reactive chemicals that can be used only for cleaning. They should be completely removed at the end of the cleaning procedure. Perform the cleaning in well-ventilated premises or outdoors. You should use gloves and eye protection. Avoid thickening of the lubricant in the bolt channel for the firing pin, in the seat for the extractor, on the mainspring, and the firing pin spring.

For best results we recommend to use Kalashnikov cleaning products and lubricants available online at shop.kalashnikov.com. When using the carbine, do not lubricate magazines.

4 STORAGE

- 4.1 To maintain in good operating order, keep the carbine always cleaned and lubricated with a thin coat of the Kalashnikov gun oil.
- 4.2 To avoid the mainspring permanent deformation, keep the hammer released.
- 4.3 Store the carbine in dry premises without sharp temperature changes, far from heating devices and without aggressive substances in the ambient air.

5 TRANSPORTATION

5.1 The carbine may be transported by any transport in covered transport facilities. While transporting, keep the carbine cased and protect it from impacts and falls.

6 COMPLETE SET

6.1 The carbine complete set is specified in Table 2.

Table 2

Designation	Description	Qty, pcs
ИЖ-173.С6	Carbine (without magazine)	1
ИЖ-173.С66	Magazine	2
	<u>Tools and accessories</u>	
СОК-Ю-5.С63	Oiler	1
СОК-Ю-5.С64	Pull-through	1
СОК-Ю-5.С65	Brush	1
СОК-Ю-5.2-2	Drift	1
СОК-Ю-5.3	Cleaning rod	1
	<u>Replacement parts</u>	
СОК-5.2-8	Firing pin spring	1
	<u>Operation documents</u>	
ИЖ-173 РЭ	MR1 semi-automatic hunting carbine in 7.62x54R Service Manual	1
	<u>Package</u>	
УК-2.1-1	Cardboard box	1

JSC "CONCERN "KALASHNIKOV"
PROYEZD IM. DERYABINA 2/193,
OFFICE 78
IZHEVSK, UDMURT REPUBLIC 426006
RUSSIA

TEL./FAX: + 7 (3412) 51-22-25
HOTLINE 8-800-200-1807

WWW.KALASHNIKOVGROUP.RU

